

**TECHNICAL MANUAL**

**OPERATOR'S, ORGANIZATIONAL, DIRECT  
SUPPORT AND GENERAL SUPPORT  
MAINTENANCE MANUAL**

**TOPOGRAPHIC SUPPORT SYSTEM  
TRAILER (ADCOR)  
NSN: 2330-01-076-4797**

This copy is a reprint which includes  
current pages from Change 1.



CHANGE }  
NO. 1 }

HEADQUARTERS  
DEPARTMENT OF THE ARMY  
WASHINGTON, D. C., 31 March 1993

OPERATOR'S ORGANIZATIONAL, DIRECT  
SUPPORT AND GENERAL SUPPORT  
MAINTENANCE MANUAL

TOPOGRAPHIC SUPPORT SYSTEM  
CHASSIS, SEMI-TRAILER  
NSN: 2330-01-076-4797

DISTRIBUTION STATEMENT A: Approved for public release; distribution is unlimited

TM 5-2330-305-14, 20 February 1987, is changed as follows:

1. Remove and insert pages as indicated below. New or changed text material is indicated by a vertical bar in the margin. An illustration change is indicated by a miniature pointing hand.

Remove pages

InSert pages

5-9 and 5-10

5-9 and 5-10

2. Retain this sheet in front of manual for reference purposes.

By Order of the Secretary of the Army:

GORDON R. SULLIVAN  
*General, United States Army*  
Chief of Staff

Official:

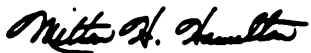
  
MILTON H. HAMILTON  
Administrative Assistant to the  
Secretary of the Army

62817

DISTRIBUTION:

To be distributed in accordance with DA Form 12-25-E, block no. 2344, requirements for TM 5-2330-305-14.

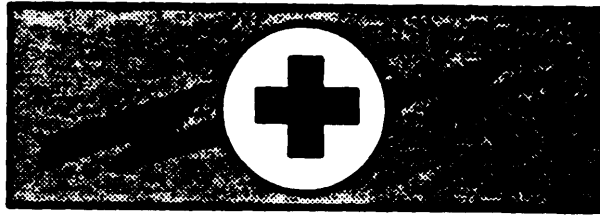

**WARNING**

DEATH or severe injury to personnel and/or damage to property may result if personnel fail to observe safety precautions.

When lifting trailer under the axle, use jacks with heads large enough to distribute load.

If spring brakes are caged, deactivated or removed, the trailer will have no emergency or parking brakes and must not be driven in traffic or parked without blocking wheels.

Be sure that ISO container is locked to trailer before attempting to move trailer.

Use lifting and moving equipment in good repair to prevent personnel injuries.

Do not remove or disassemble brake chamber or clevis without caging brakes.

Cleaning solvent is potentially dangerous. Avoid repeated and prolonged skin contact and breathing of vapors. Use in well ventilated area. Cleaning solvent is toxic, volatile and combustible.

Do not work on pneumatic components without repressurizing air system



**OPERATORS, ORGANIZATIONAL, DIRECT SUPPORT  
AND  
GENERAL SUPPORT MAINTENANCE MANUAL**

**CHASSIS, SEMITRAILER**

**REPORTING OF ERRORS**

You can help improve this manual. If you find any mistakes or if you know of a way to improve the procedures, please let us know. Mail your letter or DA Form 2028 (Recommended Changes to Publications and Blank Forms) or DA Forms 2028-2, located in the back of this manual, direct to: Commander, Troop Support and Aviation Materiel Readiness Command, ATTN: DRSTS-tlPSD, 4300 Goodfellow Blvd, St Louis, MO 63120. A reply will be furnished to you.

TABLE OF CONTENTS

		Page
CHAPTER 1.	Introduction . . . . .	1-1
Section I.	General Information . . . . .	1-1
Section II.	Equipment Description and Data . . . . .	1-1
Section III.	Technical Principles of Generation . . . . .	1-8
CHAPTER 2.	OPERATING INSTRUCTIONS . . . . .	2-1
Section I.	Description and Use of Operator's Controls and Indicators. . . . .	2-1
Section II.	Operator's Preventive Maintenance Checks and Services(PHCS) . . . . .	2-6
Section III.	Operation Under Usual Conditions . . . . .	2-10
Section IV.	Operation Under Unusual Conditions . . . . .	2-17
CHAPTER 3.	OPERATOR/CREW MAINTENANCE INSTRUCTIONS . . . . .	3-1
Section I.	Lubrication Instructions . . . . .	3-1
Section II.	Troubleshooting . . . . .	3-1
Section III.	Maintenance Procedures . . . . .	3-2
CHAPTER 4.	ORGANIZATIONAL MAINTENANCE INSTRUCTIONS . . . . .	4-1
Section I.	Repair Parts, Special Tools and Equipment . . . . .	4-1
Section II.	Organizational Preventive Maintenance Checks and Services(PHCS) . . . . .	4-1
Section III.	Organizational Troubleshooting . . . . .	4-6
Section IV.	Maintenance Procedures . . . . .	4-11
Section V.	Preparation for Storage or Shipment . . . . .	4-50

TABLE OF CONTENTS (Cont)

	<b>Page</b>
CHAPTER 5. DIRECT/GENERAL SUPPORT MAINTENANCE INSTRUCTIONS . . . . .	5-1
Section I. Repair Parts, Special Tools, and Equipment . . . . .	5-1
Section II. Troubleshooting . . . . .	5-1
Section III. Maintenance Procedures . . . . .	5-2
APPENDIX A. REFERENCES. . . . .	A-1
APPENDIX B. MAINTENANCE ALLOCATION CHART . . . . .	B-1
APPENDIX C. COMPONENTS OF END ITEM AND BASIC ISSUE ITEMS LISTS . . . . .	C-1
APPENDIX D. ADDITIONAL AUTHORIZATION LIST . . . . .	D-1
APPENDIX E. EXPENDABLE SUPPLIES AND MATERIAL LISTS . . . . .	E-1
APPENDIX F. STOWAGE AND SIGN GUIDE . . . . .	F-1

LIST OF TABLES

Number	Title	Page
OPERATING INSTRUCTIONS		
2-1	Operator's Preventive Maintenance Checks and Services . . . . .	2-7
ORGANIZATIONAL MAINTENANCE INSTRUCTION		
4-1	Organizational Preventive Maintenance Checks and Services. . . . .	4-2
4-2	Organizational Troubleshooting . . . . .	4-6





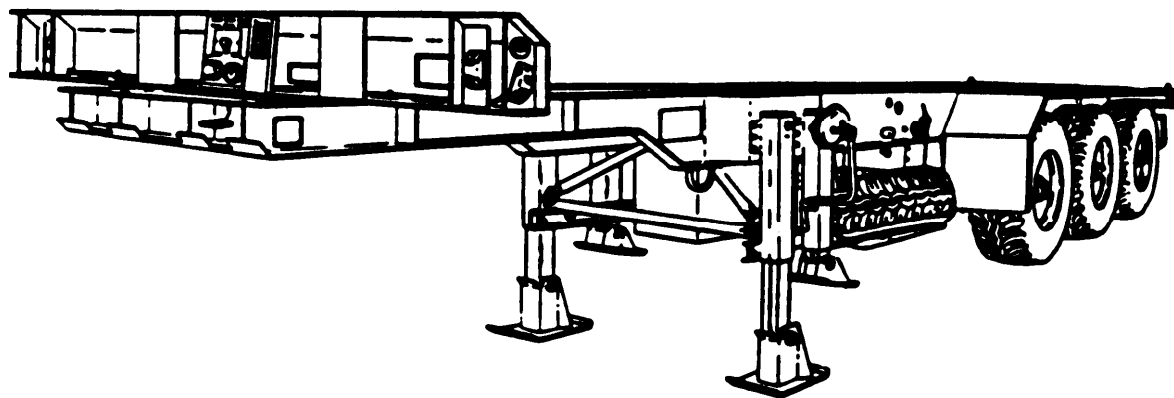

## CHAPTER 1

### INTRODUCTION

#### Section I. GENERAL INFORMATION

**1.1.1 SCOPE.** This manual contains operation and maintenance instructions to be performed at Operator, Organizational, and Direct/General Support maintenance levels. These instructions pertain to the ADCOR 13225E3025 Semitrailer Chassis. The trailer provides for the support, retention and transportation of a standard 30 ft (9000 mm) van body.

**1.1.2 MAINTENANCE FORMS AND RECORDS.** Maintenance forms and records that are required are as follows:

DA Form 2404 Equipment Inspection and Maintenance worksheet

DA Form 2407 Maintenance Request Used for Requesting Support Maintenance

For further information, refer to TM 38-750, The Army Maintenance Management System (TAMMS).

**1.1.3 REPORTING EQUIPMENT IMPROVEMENTS (EIR's).** If the trailer manual needs improvement, let us know. Send us an EIR You, the user, are the only one who can tell us what you do not like about your equipment. Let us know why you do not like the design or performance. Put it on an SF-368 (Quality Deficiency Report). Mail it to us at: Troop Support and Aviation Material Readiness Command, ATTN: DRSTS-HEH, 4300 Goodfellow Blvd, St Louis, MO 63120. We will send you a reply.

**1.1.4 WARRANTY INFORMATION.** This trailer has no items under warranty.

#### Section II. EQUIPMENT DESCRIPTION AND DATA

##### 12.1 EQUIPMENT PURPOSE, CAPABILITIES, AND FEATURES

###### Purpose

Provide a means of supporting, retaining and transporting a standard 30 ft (9000 mm) van body over primary highways, secondary roads, open fields, rolling hills and rough, off-road terrain.

Capabilities and Features

All-weather operational.

Independent corner leveling jacks for all parking surface applications.

After spring suspension for a soft, level ride under all conditions.

Heavy-duty shock absorbers which promote longer tire life and smoother ride.

Automatic ride height control maintaining trailer frame-to-axle clearance with varying loads.

Emergency air brake system.

Positive van body-to-trailer bayonet-type twist locks.

Hubodometer for accurate mileage recording.

Spacious tool compartment.

Tri-axle suspension with high flotation, tubeless tires.

High yield point, all welded steel construction frame.

Automatic brake adjusters.

Air and sea transportable.

1.2.2 LOCATION AND DESCRIPTION OF MAJOR COMPONENTS

1.2.2.1 FRONT AND ROADSIDE

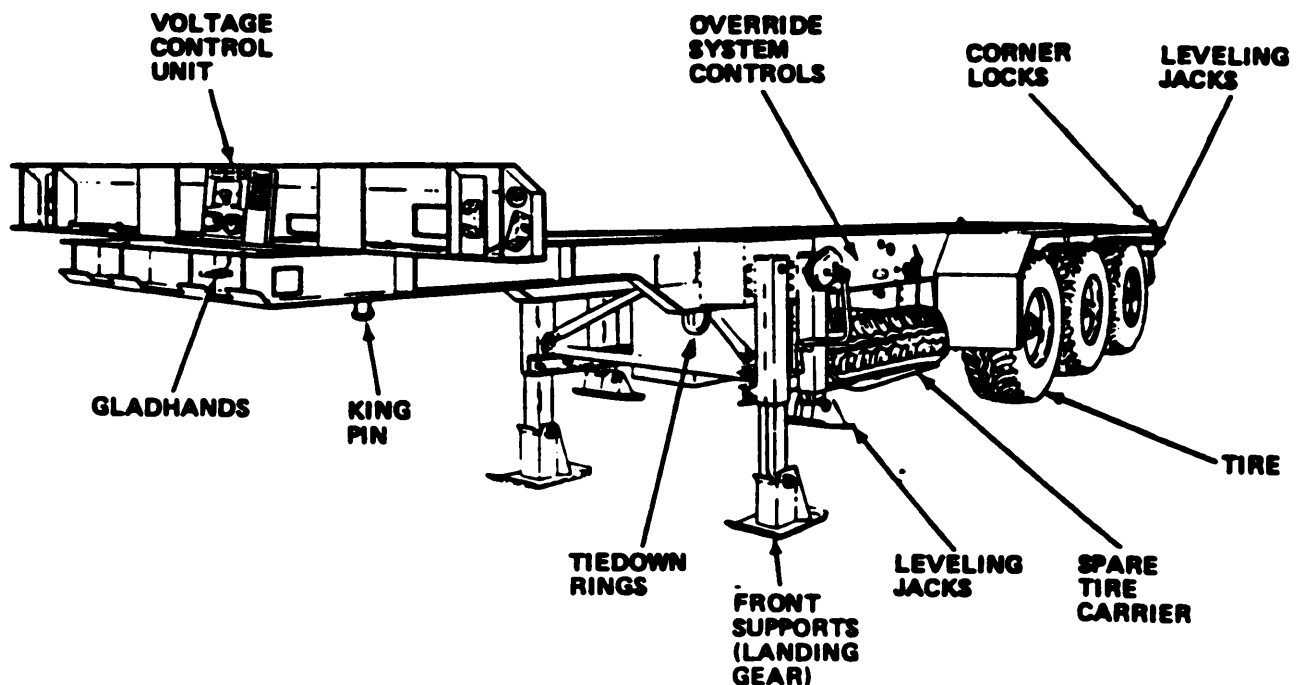

VOLTAGE CONTROL UNIT. Provides for 12 Vdc or 24 Vdc electrical interconnect between tractor and trailer chassis.

OVERRIDE SYSTEM CONTROLS. Provide operator with manual control over air suspension system.

CORNER LOCKS. Secure van body to trailer.

LEVELING JACKS. Individually operated, mechanical, telescopic jacks which provide leveling of trailer on rough or uneven surfaces.

TIRES. Size 18-22.5, tubeless, 18-ply tires.

SPARE TIRE CARRIER. Retains spare tire.

FRONT SUPPORTS (LANDING GEAR). Twin telescopic, adjustable support legs with wide mud shoes. Provide support of trailer when tractor is detached.

TIEDOWN RINGS. Provide fixed attach points to secure trailer for shipment.

KING PIN. A pivot pin which mates with fifth wheel assembly of tractor.

GLADHANDS. Provide for normal service and emergency air line interconnect between tractor and trailer chassis.

### 1.2.2.2 REAR

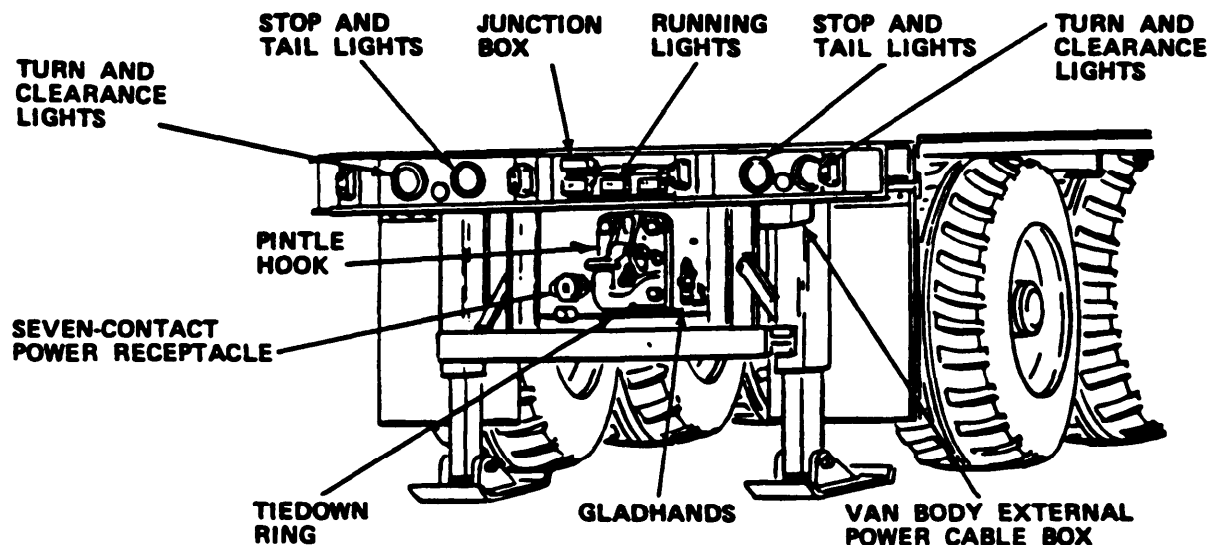

TURN AND CLEARANCE LIGHTS. Circular, red-lensed, double-filament, combination turn and clearance lights.

STOP AND TAIL LIGHTS. Circular, red-lensed, double-filament, combination stop and tail lights.

**JUNCTION BOX.** Provides for interconnect between chassis basic electrical system and 12 Vdc line to van body external power cable box.

**RUNNING LIGHTS.** Rectangular red-lensed lights.

**VAN BODY EXTERNAL POWER CABLE BOX.** Houses 12 Vdc, two-lead electrical cable assembly which provides interconnect between trailer power supply and van body interior dome lights.

**GLADHANDS.** Provide for service and emergency air lines interconnect between trailer and additional towed vehicle.

**TIEDOWN RING.** Provides fixed attach point to secure trailer for shipment.

**SEVEN-CONTACT POWER RECEPTACLE.** Provides for 12 Vdc electrical power interconnect between trailer and additional towed vehicle.

**PINTLE HOOK** Spring-locked hook provides attach point for towing-of additional vehicle.

### 1.2.2.3 CURBSIDE

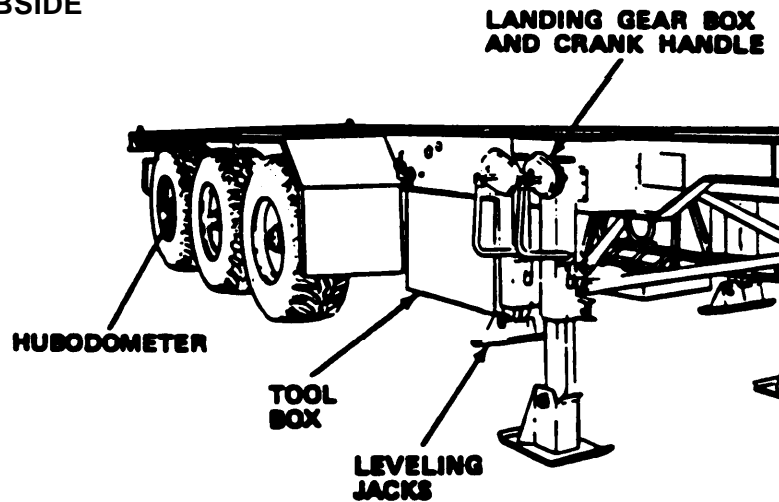

**LEVELING JACKS.** Mechanical telescopic jacks which provide leveling of trailer on rough or uneven terrain.

**LANDING GEAR BOX AND CRANK HANDLE.** Device used to manually raise and lower front supports.

**TOOLBOX.** Provides for storage of tools, jack, etc.

**HUBODOMETER.** Converts wheel rotations into mileage readings.

### 1.2.2.4 INTERFRAME

**BRAKE VALVES.** Brake application and release chambers. Mechanically attached through linkage to S-cam actuated brake shoes. Valves are air diaphragm operated.

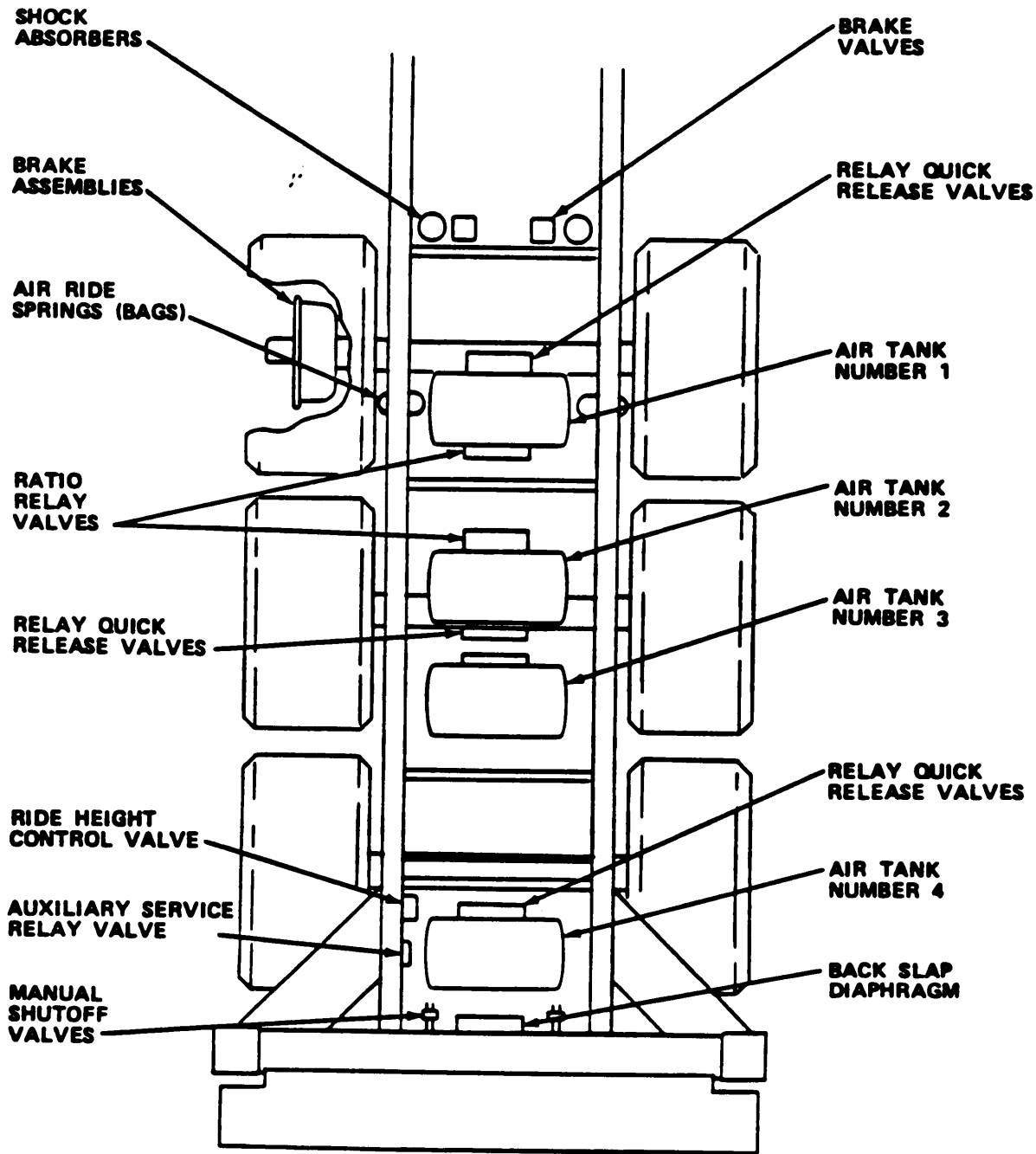

RELAY QUICK RELEASE VALVES. One for each pair of wheel brakes. Control actuation and release of brake pressure.

AIR TANK NUMBER 1. Stores pressurized air used in front axle brake actuation system.

AIR TANK NUMBER 2. Stores pressurized air for center axle brake actuation system.

AIR TANK NUMBER 3. Stores pressurized air for air ride system only.

AIR TANK NUMBER 4. Stores pressurized air for rear axle brake actuation system.

BACK SLAP DIAPHRAGM. Provides pintle hook with load dampener when towed vehicle is attached to trailer.

MANUAL SHUTOFF VALVES. Means of shutting off trailer air supply to rear gladhands.

AUXILIARY SERVICE RELAY VALVE. Provides brake control over auxiliary towed vehicle.

RIDE HEIGHT CONTROL VALVE. Automatically maintains a preset clearance between trailer frame and axles by either inflating or deflating air ride springs.

RATIO RELAY VALVES. One for each pair of wheel brakes. Sense and maintain differential between control and emergency air pressures required for proper brake functioning.

AIR RIDE SPRINGS (BAGS). Two air-filled, rubber bags per axle provide a desired load height and a soft, level ride under all conditions.

BRAKE ASSEMBLIES. Consists of riveted brake linings, springs and associated hardware. Self-adjustors ensure proper brake lining contact.

SHOCK ABSORBERS. Two large bore shock absorbers per axle keep tires in constant contact with road and dampen sudden shocks.

### 1.2.3 EQUIPMENT DATA

#### Dimensions

Width	8 ft. 0 in. (2.44 m)
Height	4 ft. 6 in. (1.37 m)
Length	33 ft. 6 in. (10.2 m)
Maximum Gross Weight	11,440 lbs. (5189 kg)

#### Power Requirements

Primary Power	12 Vdc commercial system (negative ground) or 24 Vdc military system
---------------	--



Wheels and Tires

Wheel Type

Firestone Duplex Disc wheels

Tire Type and Size

Firestone Duplex Super All Traction 18/22.5; 18-ply rating; load rating J; B-329 tubeless

Tire Pressure

90 psi (6.33 kg/cm<sup>2</sup>)

Weight Distribution

No axle is loaded in excess of 20,000 lb (9072 kg)

SAE J701 Interchange Coupling Dimensions

Radius (LCW)

90 in. (2.29 m)

Swing Radius (SR)

58 in. (1.47 m)

Kingpin Setting (KP)

Range 24 to 36 in. (0.61 to 0.91 m)

Height (FWH)

52 in. (1.3 m)

**Section III. TECHNICAL, PRINCIPLES OF OPERATION**

**1.3.1 MAIN FRAME ASSEMBLY** A ladder-type, welded steel frame which forms the basic structure of the chassis. The toolbox and spare tire carrier are bolted to the frame rails. The suspension system is mounted under the rails and welded steel fenders contain rock and mud guards. The pneumatic and electrical systems are mounted to the frame at various points.

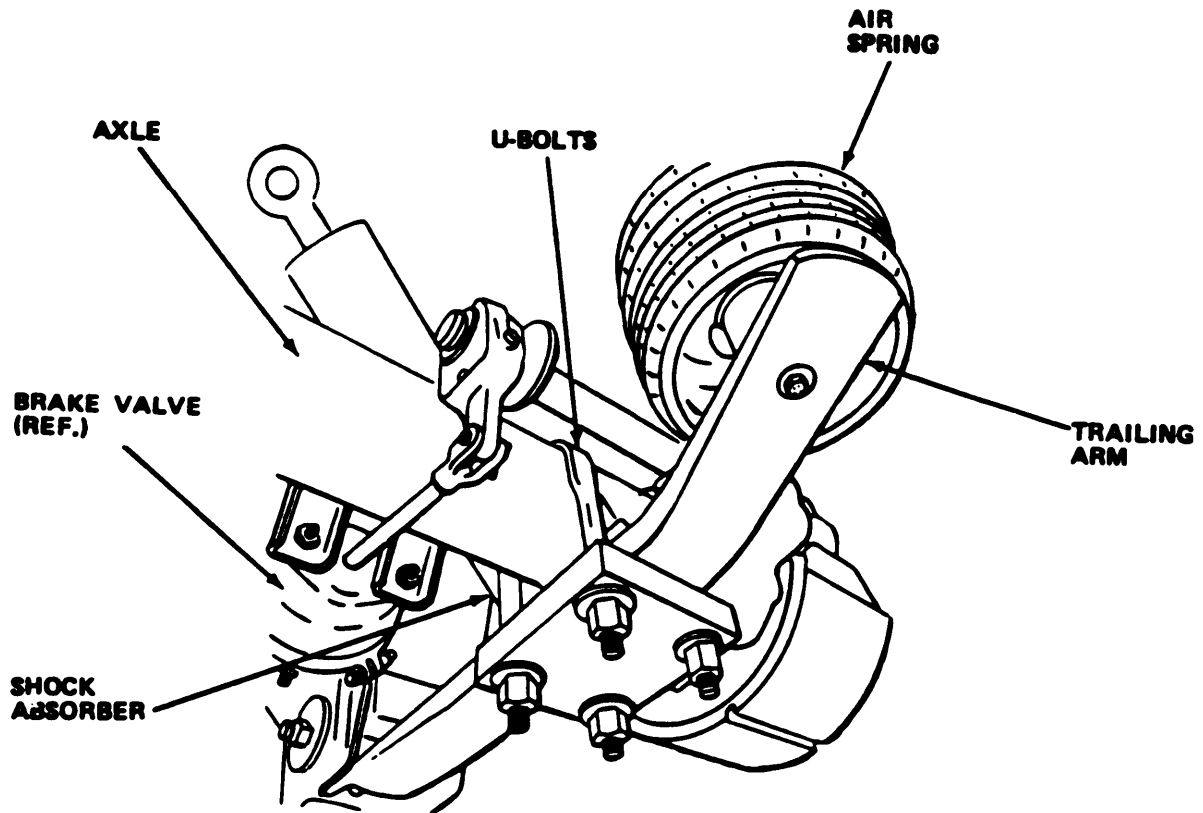

**1.3.2 SUSPENSION SYSTEM.** The tridem (3-axle) suspension consists of parallel trailing arms to which the axle is bolted. Pneumatic air bags are connected between the trailing arms and frame to cushion the load and maintain proper ride height. Shock absorbers are mounted between frame and axle to provide better control over rough roads by absorbing sudden shock.

**1.3.3 BRAKE SYSTEM.** Stops wheel rotation with internal expanding brake shoes. A cam driven by the brake chamber through a linkage arrangement expands the shoes against the drum. The brake chamber, utilizing pressure differentials, determines the amount of force the cam applies to the shoes. An automatic slack adjuster maintains proper linkage adjustment. The brake shoes are the riveted type and can be refaced.

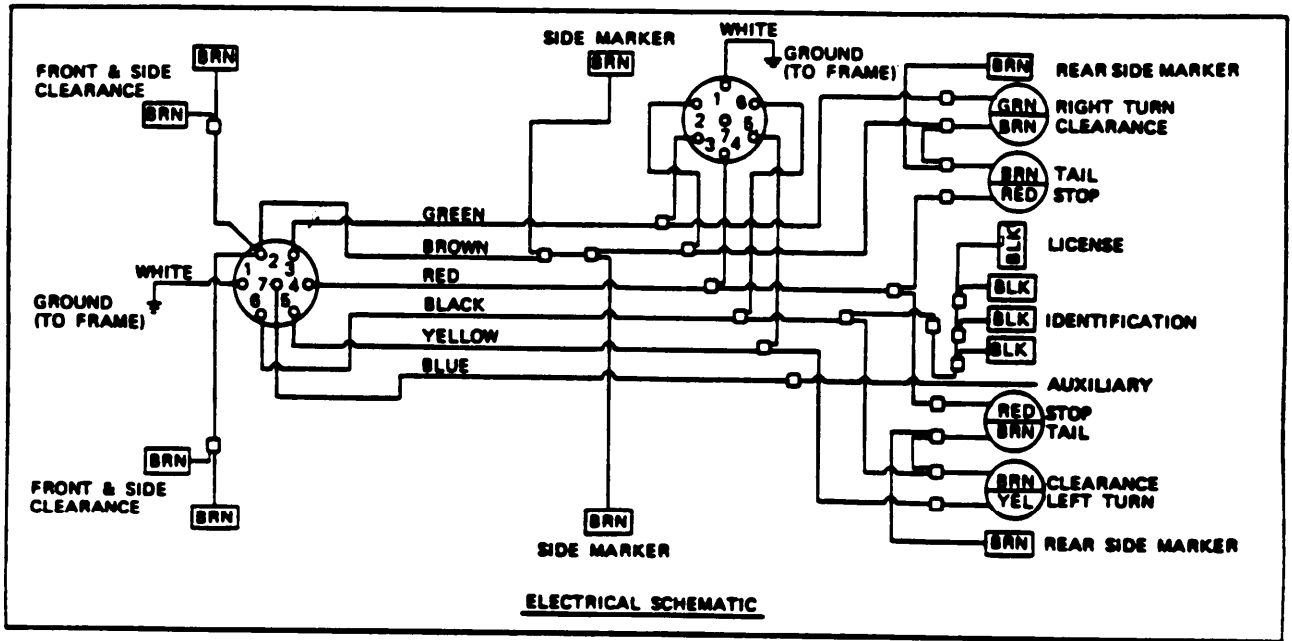

**1.3.4 ELECTRICAL SYSTEM** Provides power for the illumination of chassis lights. All power and control is supplied by the towing vehicle through a seven prong male plug located on the chassis front crossmember. Each prong supplies power as follows:

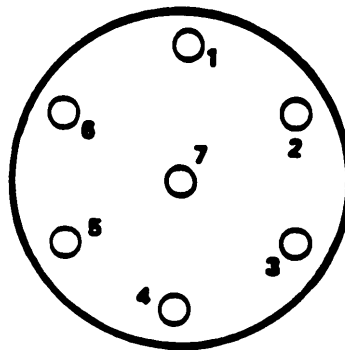

Prong Number	Application
1	Grounded to chassis frame.
2	To front and side clearance lights, side marker lights and right rear side marker, clearance and tail lights.
3	Right turn signal light.

Prong Number	Application
4	Rear stop lights.
5	Left turn signal light.
6	To left rear side marker, clearance and tail lights, rear identification and license plate lights.
7 (center)	Auxiliary line.

A voltage control unit located at the front of the chassis allows either 12 Vdc or 24 Vdc tractor power supply to be used.

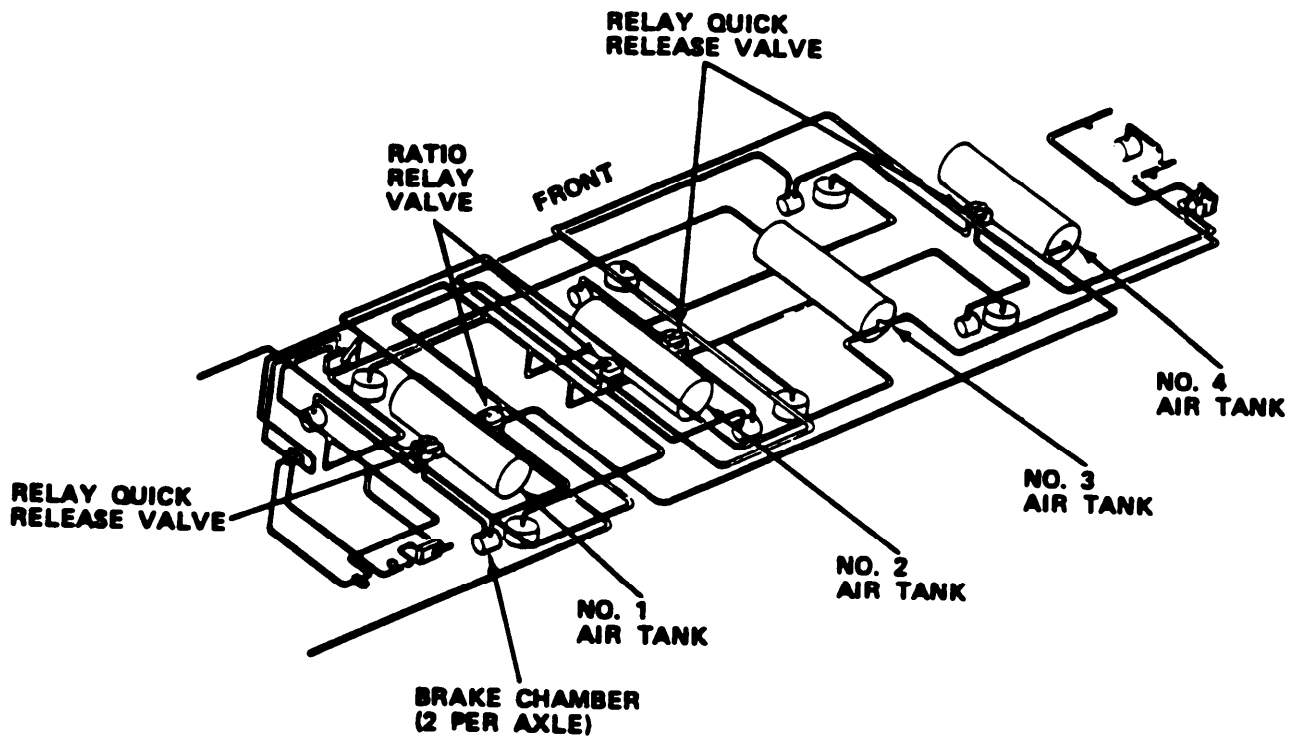

**1.3.5 PNEUMATIC SYSTEM.** Controls the braking and air ride systems. It consists of:

- Air Storage Tanks (1.3.5.1)
- Rel ay Qui ck Rel ease (1.3.5.2)
- Rati o Rel ay Val ve (1.3.5.3)
- Brake Chamber (1.3.5.4)
- Auxi li ary Servi ce Rel ay (1.3.5.5)

Height Control Valve (1.3.5.6)

Override Assembly (1.3.5.7)

Air Spring (1.3.5.8)

**1.3.5.1 AIR STORAGE TANKS.** Stores pressurized air for brake and air ride actuation. Tanks 1, 2 and 4 supply brake system while tank 3 supplies air ride system only.

**1.3.5.2 RELAY QUICK RELEASE VALVES.** Speeds up application and release of brakes by shortening the length of tubing which air from the brake valve must pass. It is connected directly to the air storage tanks to utilize the pressurized storage air for brake actuation.

**1.3.5.3 RATIO RELAY VALVE.** Determines pressure differential between service and emergency lines to apply or release pressure to brake chamber emergency diaphragm.

**1.3.5.4 BRAKE CHAMBER.** Through two counteracting diaphragms, converts pneumatic force to linear mechanical force. The linear force is utilized by the brake system to expand the brake shoes against the brake drum.

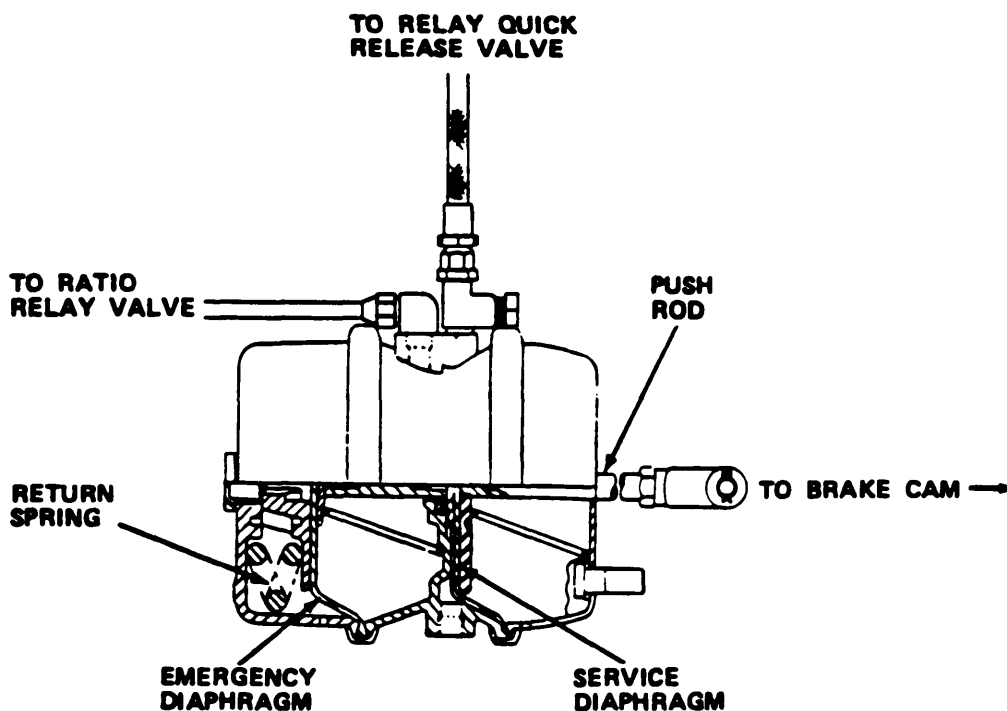

a. Emergency Diaphragm. Provides fail-safe emergency braking in the event system pressure is lost. The high pressure return spring, which provides adequate force for brake activation, is counteracted by the emergency diaphragm under normal operating conditions. The diaphragm is connected to the pushrod and controlled by the ratio relay valve.

b. Return Spring. Provides 1800 lbs (816.5 kg) of force to the pushrod for brake application. The spring is counteracted by the emergency diaphragm air pressure and extends to apply brakes if emergency air pressure decreases.

c. Service Diaphragm. Counteracts the emergency diaphragm to provide service brake application. It is connected to the pushrod and controlled by the relay quick release valve. As pressure is applied to the diaphragm, the pushrod extends to apply force to brakes.

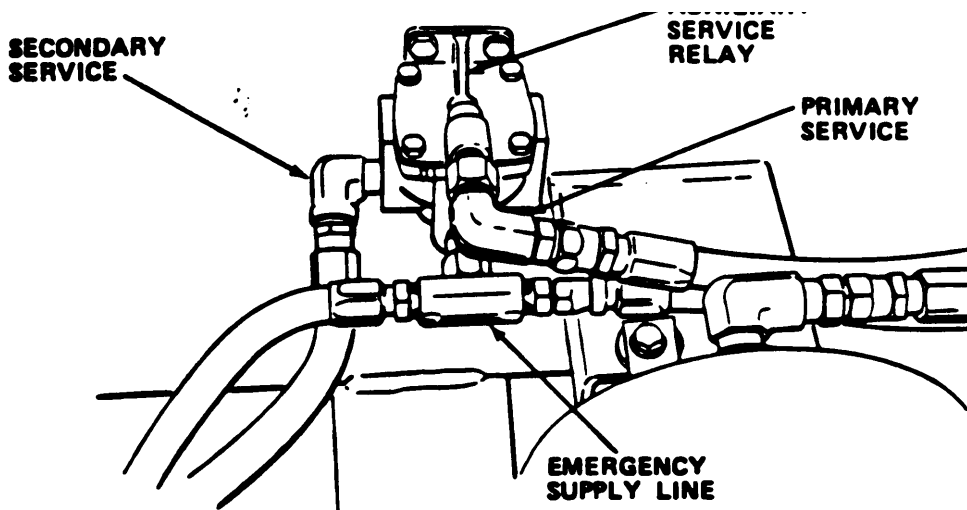

**1.3.5.5 AUXILIARY SERVICE RELAY.** Speeds up application and release of brakes on auxiliary towed trailers by shortening the length of tubing which air must pass from the brake valve. As primary brake system pressure increases, the relay opens allowing emergency system pressure to supply the secondary service system.

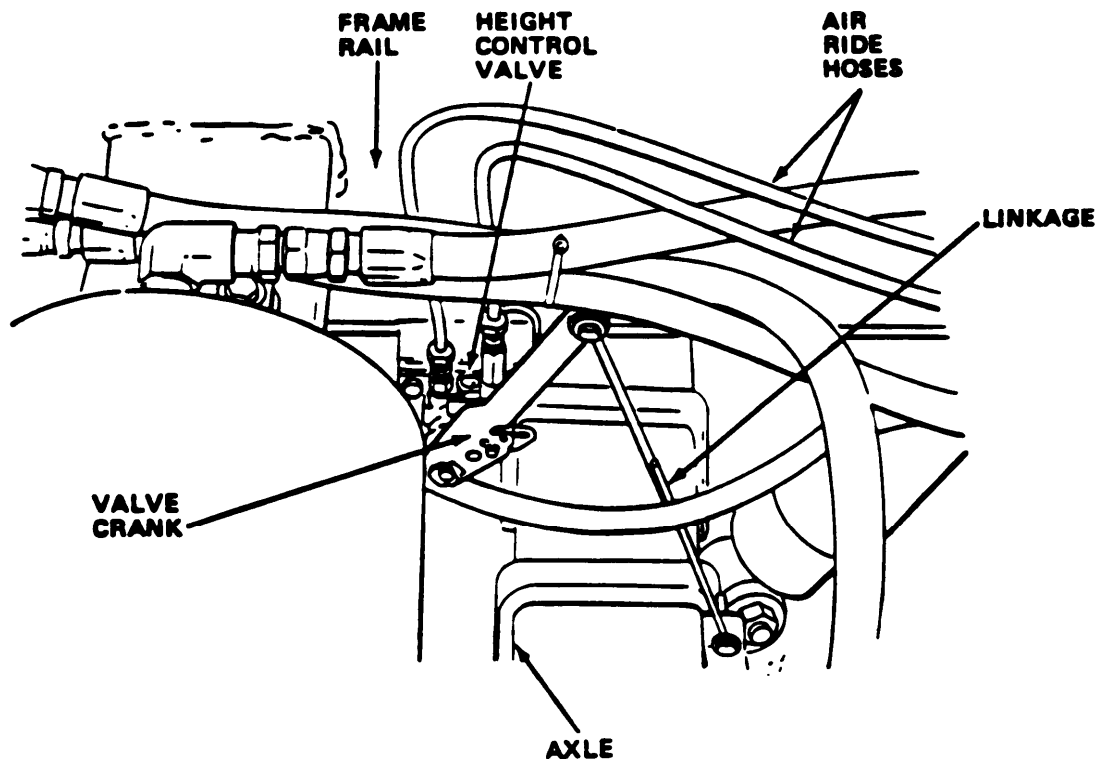

**1.3.5.6 HEIGHT CONTROL VALVE.** Maintains constant chassis ride height by determining distance between chassis frame and wheel axle. The valve opens to add or remove air in air bags.

**1.3.5.7 OVERRIDE ASSEMBLY.** Allows inflation and deflation of air springs independently of height control valve. It consists of:

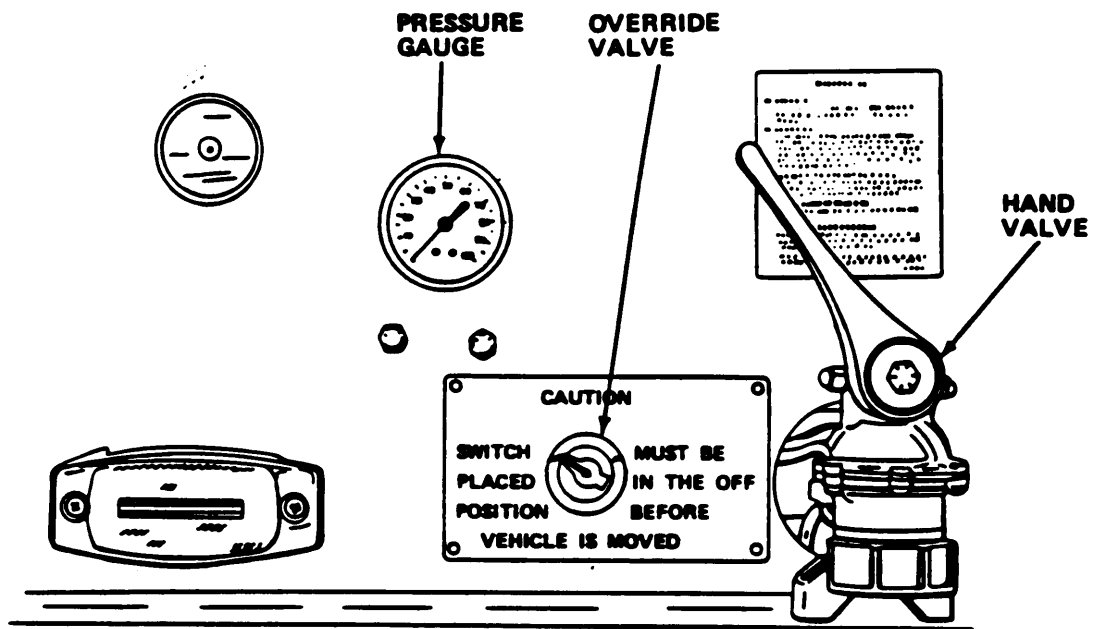

- a. Hand Valve. Allows manual filling of air spring.
- b. Override Valve. Bypasses operation of height control valve.
- c. Pressure Gage. Indicates pressure in air springs.

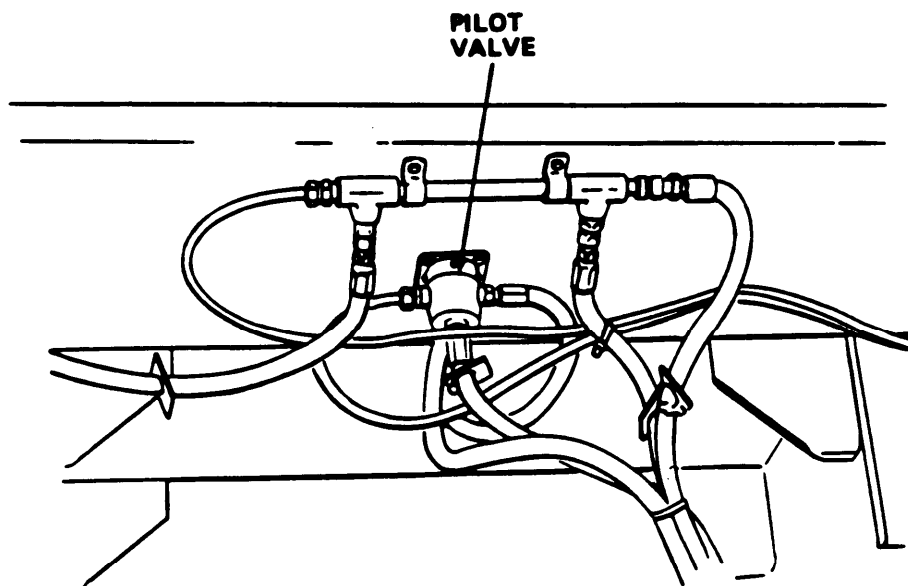

d. Pilot Valve. Utilizes override valve air signal to determine if hand valve or height control valve control air spring filling.

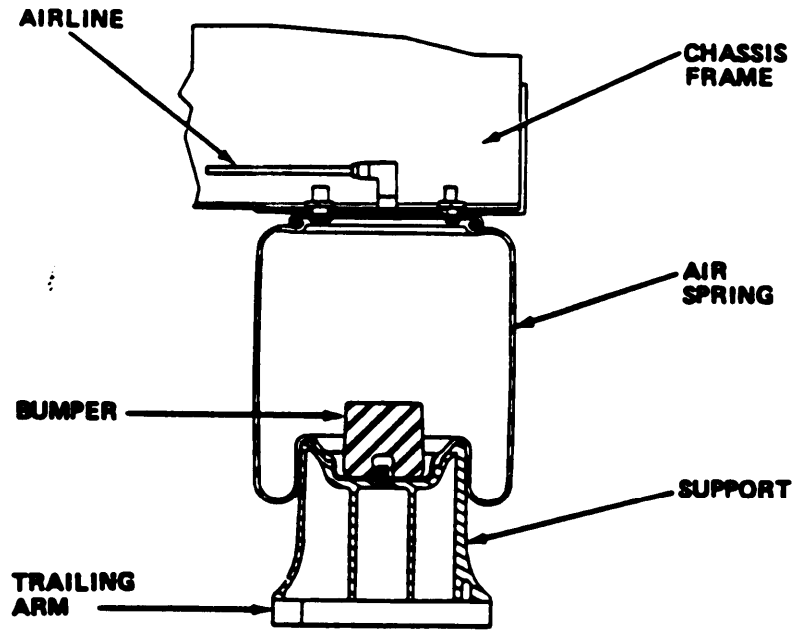

**1.3.5.8 AIR SPRING.** A flexible air-inflated chamber in which the air pressure is controlled and varied to support the load and absorb road shocks.

**1.3.6 BRAKE SYSTEM OPERATION.** The following illustrates the air flow paths during brake system operation on each axle.

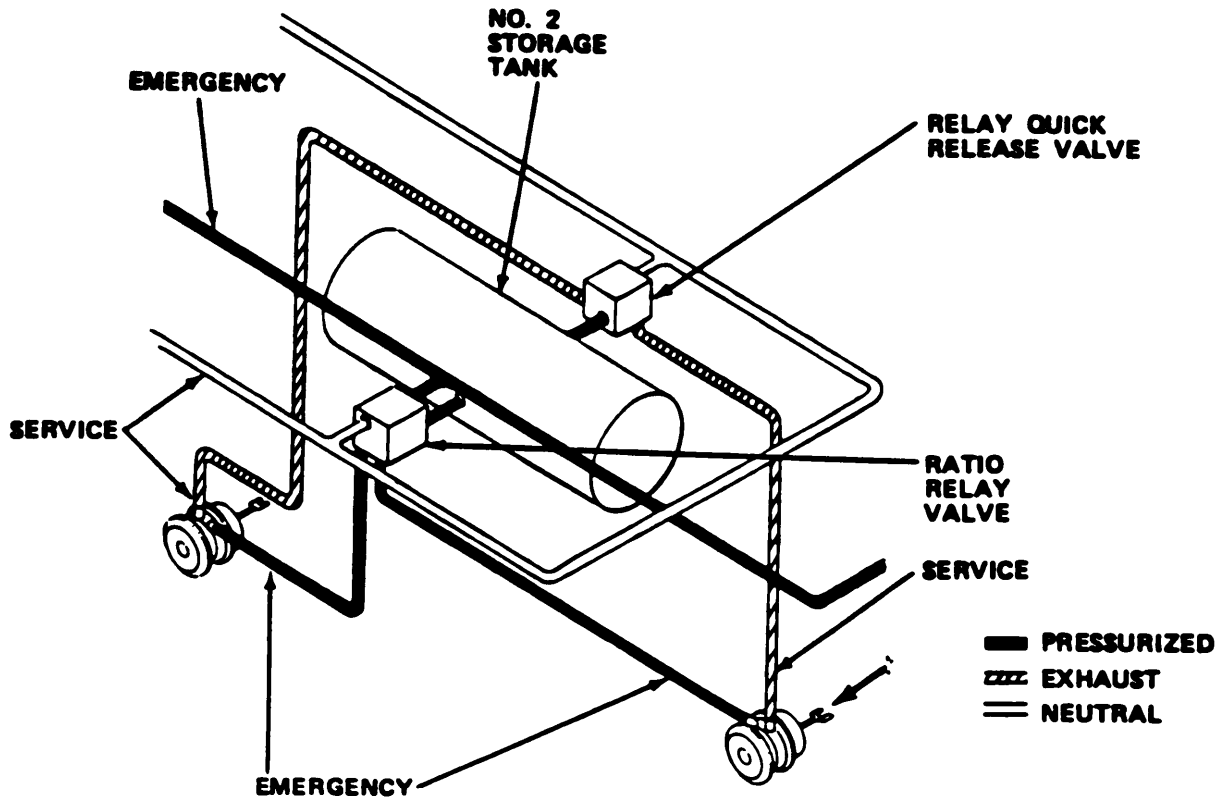



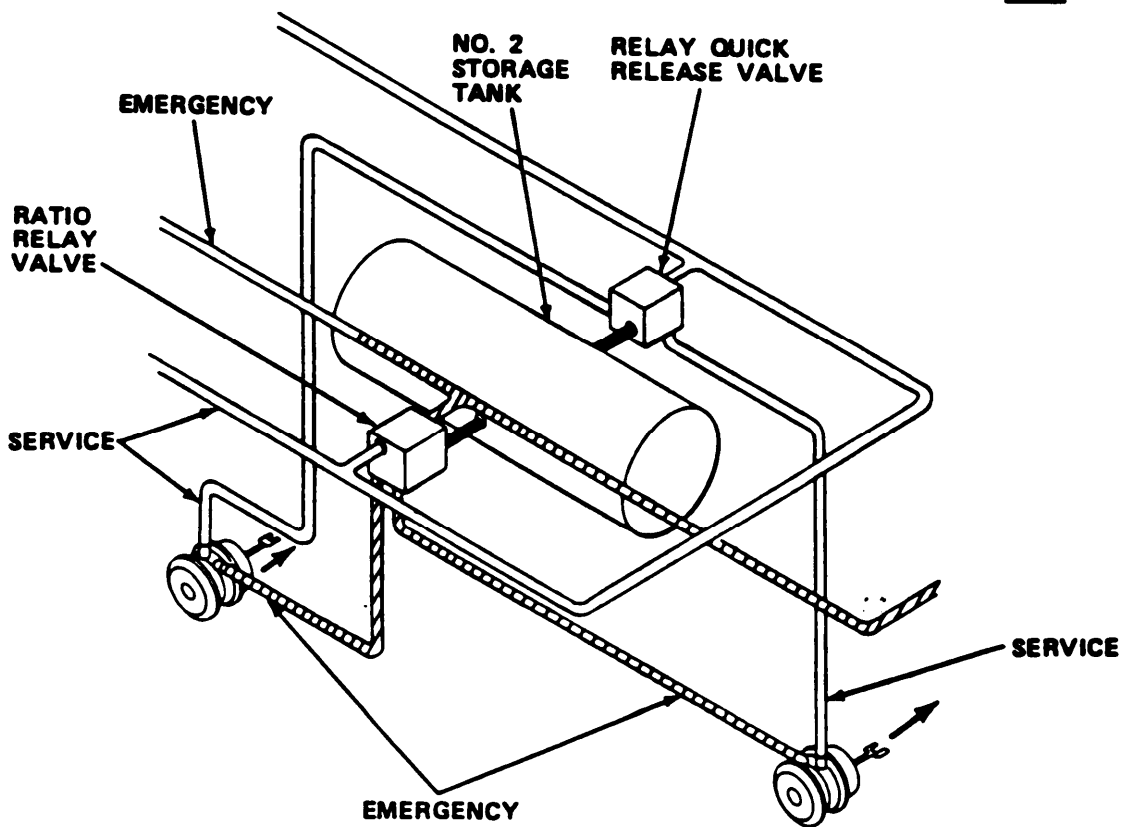
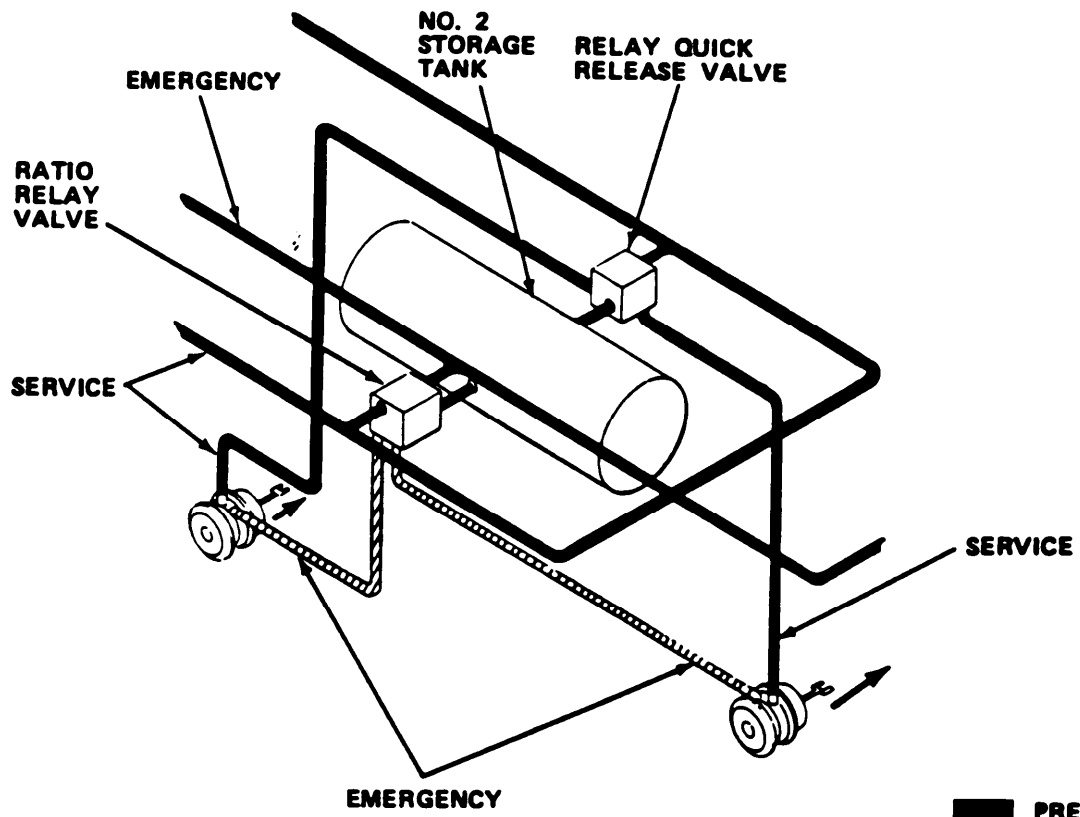

1.3.7 OVERRIDE ASSEMBLY PILOT VALVE OPERATION. The following illustrates the air flow paths during pilot valve activation and deactivation.

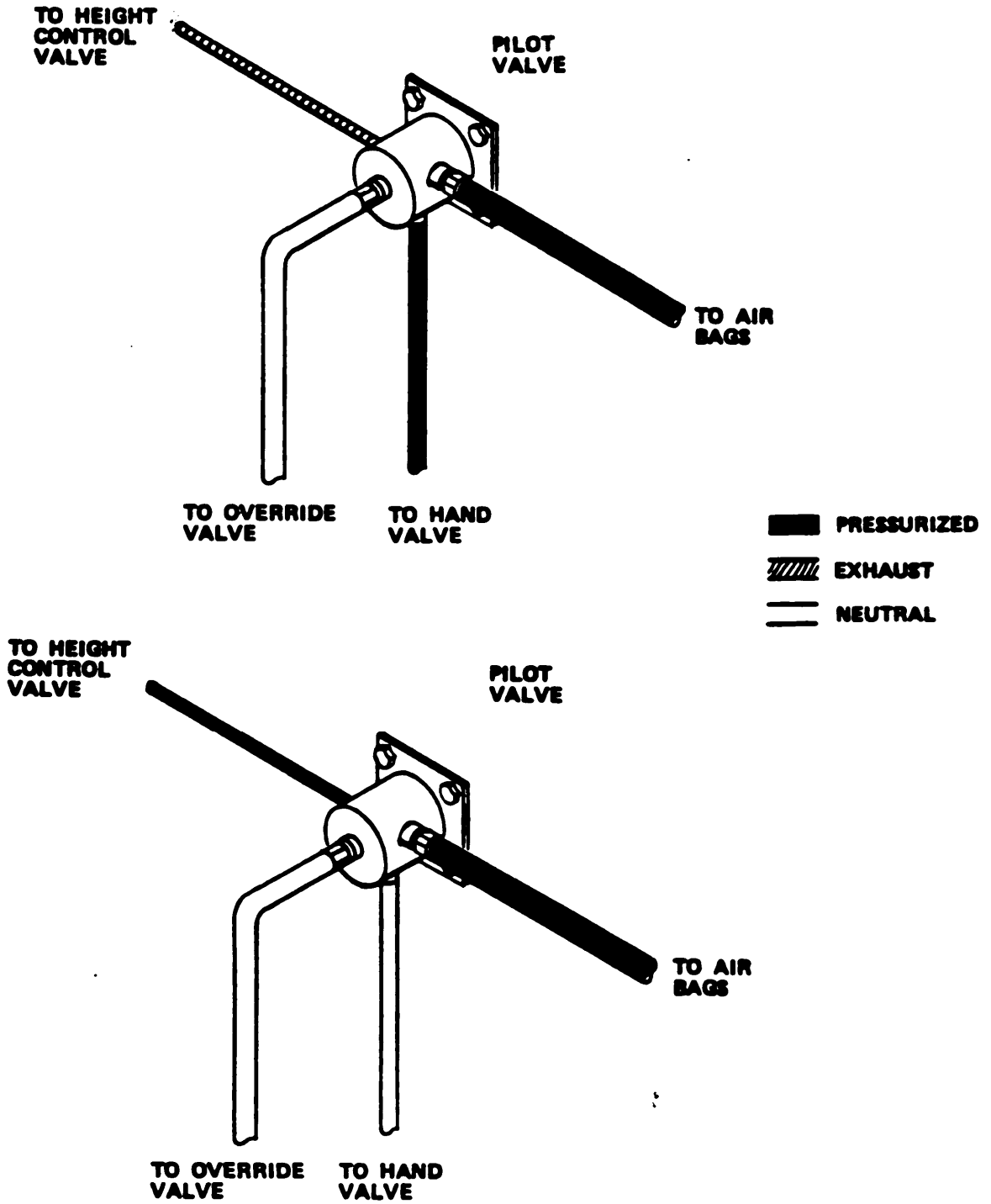

CHAPTER 2  
OPERATING INSTRUCTIONS

Section I. DESCRIPTION AND USE OF OPERATOR'S CONTROLS AND INDICATORS

2.1.1. VOLTAGE CONTROL UNIT

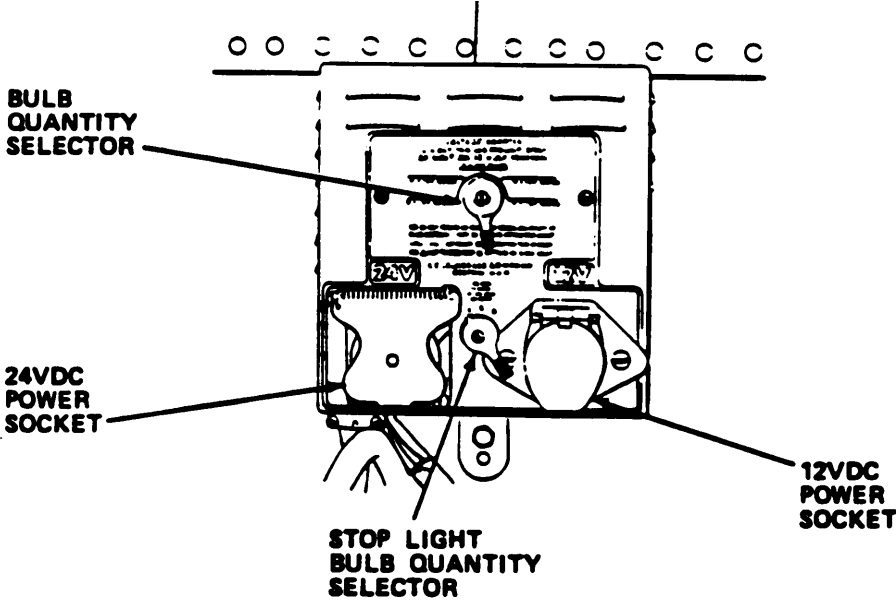

CONTROL OR INDICATOR	FUNCTION
Bulb Quantity Selector (Used only when 24 Vdc plug is installed.)	Used to adjust electrical system for number of 12 V bulbs mounted on trailer. Stop light bulbs not included.
Stop Light Bulb Quantity Selector (Used only when 24 Vdc plug is installed.)	Used to adjust electrical system for number of 12 V stop light bulbs mounted on trailer.
24 Vdc Power Socket	Interconnect point between tractor with 24 Vdc plug and trailer.
12 Vdc Power Socket	Interconnect point between tractor with 12 Vdc plug and trailer.

2.1.2. OVERRIDE ASSEMBLY

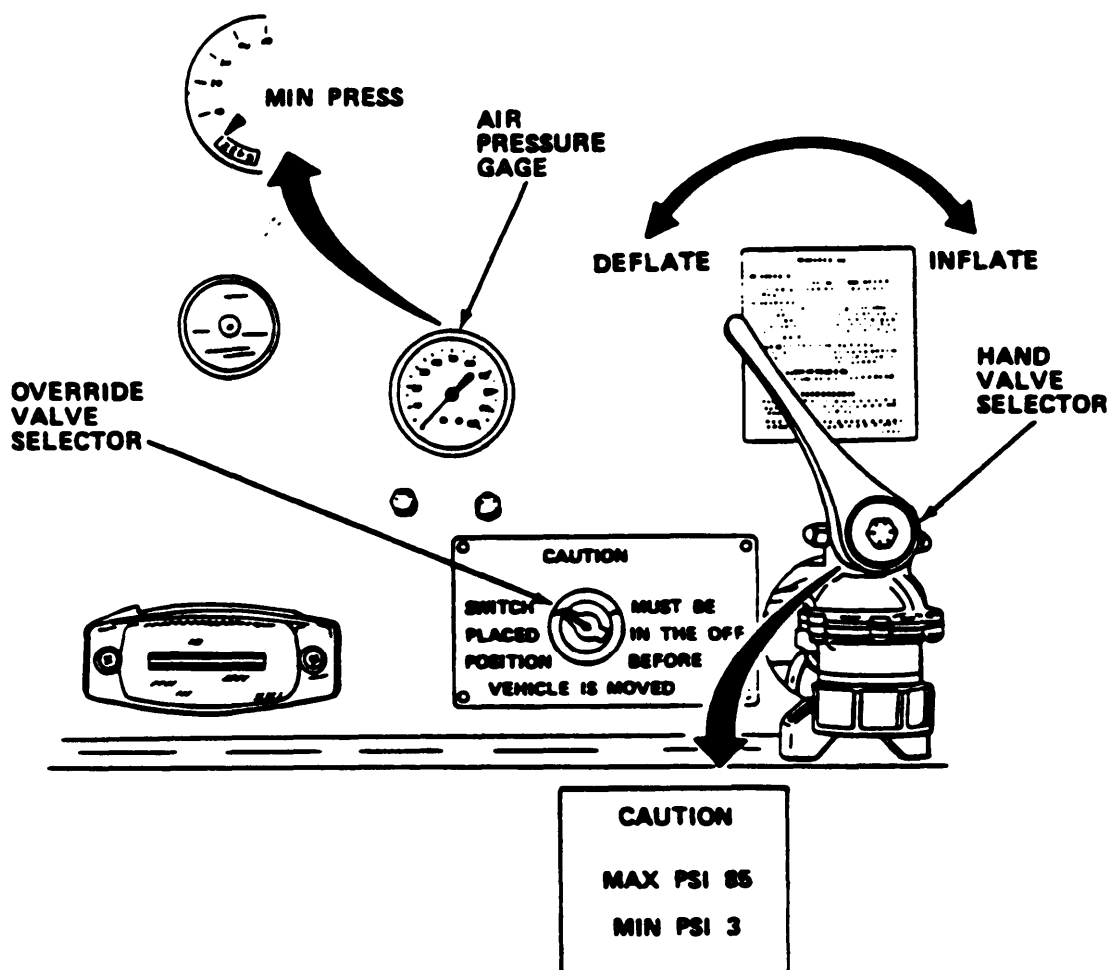

CONTROL OR INDICATOR	FUNCTION
Override Valve Selector	Two-position selector:  OFF - Air ride suspension system under control of height control valve.  ON - Height control valve deactivated. Air ride suspension system under control of hand valve.
Hand Valve Lever	Two-position lever:  RIGHT - Inflates air springs; load rises.

CONTROL OR INDICATOR	FUNCTION
Air Pressure Gage (0-100 psi in 1 psi increments)	LEFT - Deflates air springs; load lowers.  Indicates amount of pressure in air ride suspension system.

**2.1.3. SUPPORT, LEVELING AND LOCKING**

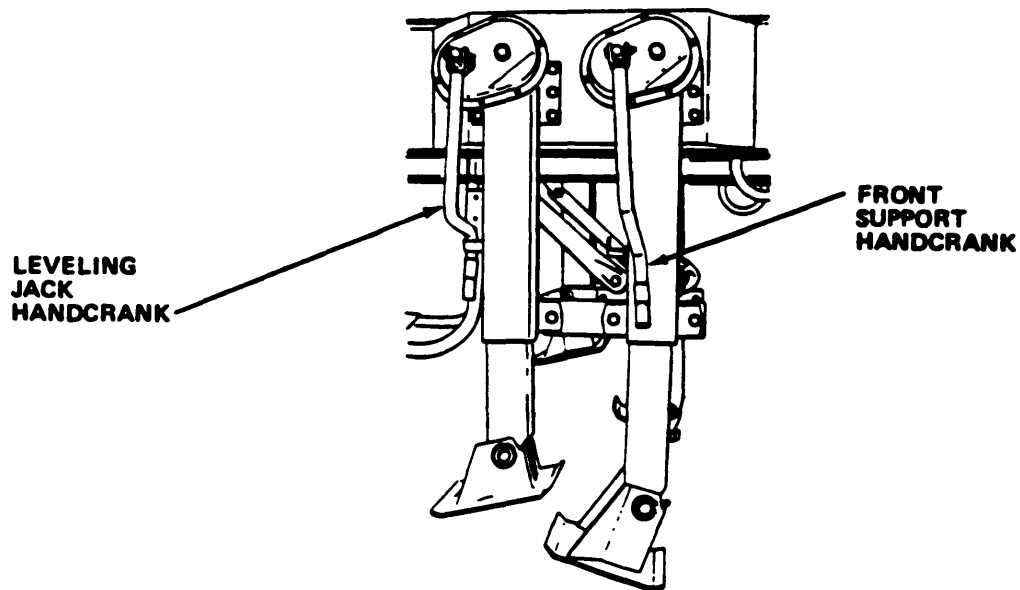

CONTROL OR INDICATOR	FUNCTION
Front Support (Landing Gear) Handcrank	Engages gearbox which raises and lowers trailer front supports.
Leveling Jack Handcrank	Engages individual gearbox which raises and lowers leveling jacks.

CONTROL OR INDICATOR

FUNCTION

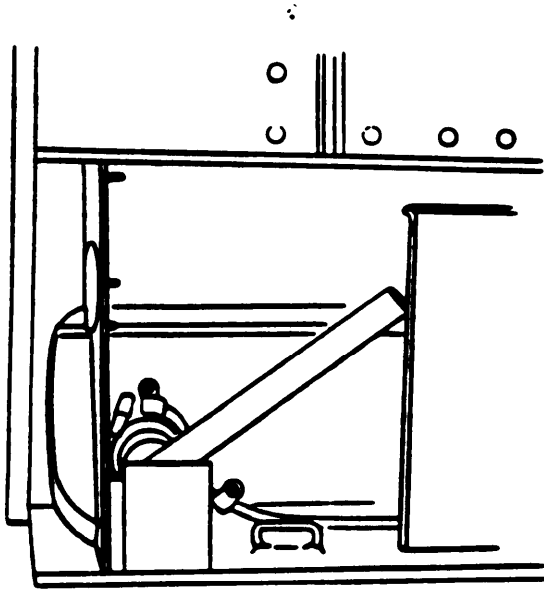

**FRONT CONTAINER LOCKS**

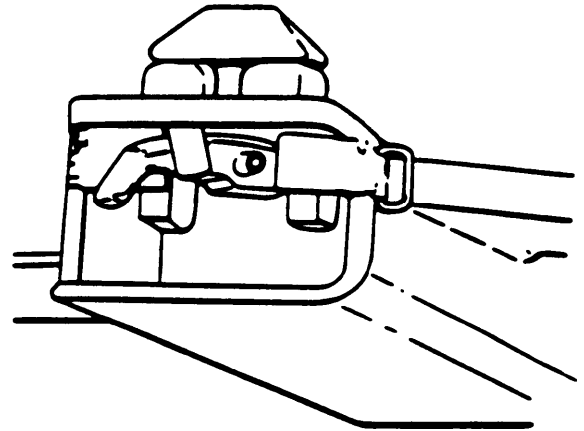

**REAR CONTAINER LOCKS**

Corner Lock Securing  
Lever

Provides means of secur-  
ing van body to trailer.

**2.1.4 AIR STORAGE TANK MOISTURE EJECTOR LANYARDS**

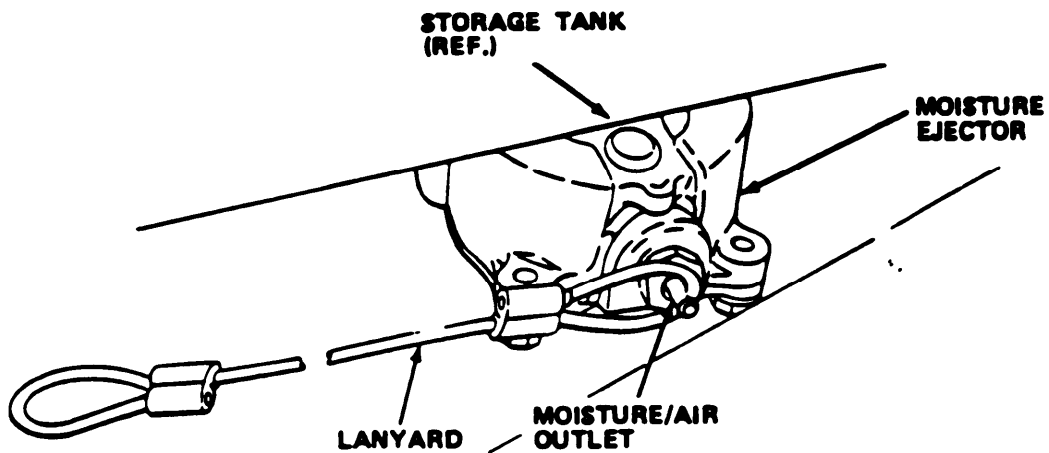

Provide means of removing moisture and/or air from air storage tanks. Lanyards are attached to moisture ejector valves and bottom of roadside rail of following locations: no. 1 tank behind no. 1 tire, no. 2 and 3 tanks behind no. 2 tire and no. 4 tank behind no. 3 tire.

#### 2.1.5 HUBDOMETER

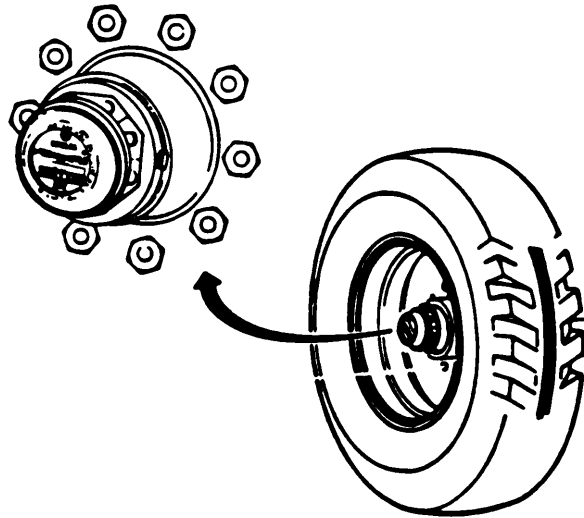

Converts no. 3 axle curbside wheel rotation to miles. Records miles to six digits and tenths of miles.

**Section II. OPERATOR'S PREVENTATIVE MAINTENANCE CHECKS AND SERVICES**

**2.2.1 INTRODUCTION**

- a. Always keep in mind the WARNINGS and CAUTIONS when performing PMCS. Table 2-1 lists the PMCS procedures to be performed by the operator. Be sure to perform the PMCS at the frequency indicated by the INTERVAL codes in the table.
- b. If your equipment fails to operate, troubleshoot with the proper equipment. Report any deficiencies in accordance with TM 38-750.

**NOTE**

If the equipment must be kept in continuous operation, check and service only those items that can safely be checked and serviced without disturbing operation. Make the complete checks and services when the equipment can be shut down.

- c. The numbers found in the ITEM NUMBER column shall be used as a source of item numbers for the TM NUMBER column on DA Form 2404, Equipment Inspection and Maintenance Worksheet, in recording the results of PMCS.
- d. List of tools and materials required for PMCS is as follows:

Item	Quantity
Liquid Detergent	ar
Sponge	1 ea
Plastic Pail	1 ea
Tire Pressure Gage	1 ea



**Table 2-1. OPERATOR'S PREVENTIVE MAINTENANCE CHECKS AND SERVICES**

		B - Before D - During A - After	W - Weekly M - Monthly Q - Quarterly	AN - Annually S - Semiannually BI - Biannually	(Number) - Hundreds of Hours	
ITEM NO.	INTERVAL	ITEM TO BE INSPECTED			PROCEDURE	For Readiness Repairing, Equipment Is Not Ready/ Available If:
1	B	INSPECT VEHICLE EQUIPMENT.				
		Prior to hookup of towing vehicle, check tools, mounted equipment, publications, and necessary forms.				
2	B	INSPECT TOWING CONNECTIONS.				
		1. Hook up towing vehicle.				
		2. Check kingpin and air and electrical connections.				
		3. Check for leaks.				
3	B/A	INSPECT LANDING GEAR.				
		1. Check landing gear for damage.				
		2. Engage landing gear handle and raise landing gear.				
		3. Note any binding or difficulty in raising landing gear.				
4	B/A	INSPECT ELECTRICAL SYSTEM.				
		1. Inspect wiring conduit, light assemblies, clips, receptacles, shells, grommets, and electrical access covers for correct assembly and condition.				System inoperable.
		2. Operate light control of towing vehicle. Inspect lights for operation or broken lens.				
5	B/D	INSPECT AIR TANKS, HOSES, AND PRESSURE.				
		1. Visually check and listen for leaks.				System will not hold pressure.

Table 2-1. OPERATOR'S PREVENTIVE MAINTENANCE CHECKS AND SERVICES (Cont)

		B - Before D - During A - After	W - Weekly M - MONTHLY Q - Quarterly	AN - Annually S - Semiannually BI - Biannually	(Number) - Hundreds of Hours	
ITEM NO.	INTERVAL	ITEM TO BE INSPECTED			PROCEDURE	For Readiness Reporting, Equipment Is Not Ready/ Available If:
5		(Cont).				
		2. Inspect for leaks in air brake system by stopping engine in towing vehicle when air pressure is maximum.				
		3. Note any drop in pressure on tractor gage within one minute.				
6	B	INSPECT AIR TANKS.				
		Remove water and sludge from system daily, especially during cold weather. This prevents freezing and obstruction of lines and valves.				
7	B	INSPECT AIR CHAMBERS, SPRINGS, AND SLACK ADJUSTERS.				
		Check condition of air chambers, air ride springs, and slack adjusters.				
8	B	INSPECT HUBCAPS.				
		Clean Hubcaps. Check for cracks.				
9	B	INSPECT WHEEL STUDS AND NUTS.				
		Check wheel studs and nuts. Make sure that they are in position and tight.				
10	B	INSPECT TIRES.				
		Remove all objects lodged between treads.				
11	B	INSPECT TIRE PRESSURE.				
		Check pressure. Inflate to 90 psi (6.33 kg/cm <sup>2</sup> ).				

**Table 2-1. OPERATOR'S PREVENTIVE MAINTENANCE CHECKS AND SERVICES (Cont)**

B - Before                      W - Weekly                      AN - Annually                      (Number) - Hundreds of Hours  
 D - During                      M - Monthly                      S - Semiannually  
 A - After                      Q - Quarterly                      BI - Biannually

Item NO.	IN-TER-VAL	ITEM TO BE INSPECTED  PROCEDURE	For Readiness Repairing Equipment Is Not Ready Available If:
12	B	INSPECT SPARE TIRE.  1. Check spare tire to insure it is secure within the carrier.  2. Inspect the carrier bracketing for proper mounting.	
13	B	INSPECT MUD FLAPS.  Inspect mud flaps for proper attachment, breaks and cracks.	
14	D	INSPECT TRACKING.  With the vehicle moving straight ahead, observe if there is any tendency for the trailer to wander or pull to the side. Such conditions are the result of axle misalignment or improperly adjusted wheel bearings or brakes.	Excessive wandering or pulling to one side.
15	D	INSPECT BRAKES.  Before moving apply brakes. Observe that they operate properly.	Brakes inoperative.
16	A	INSPECT PHYSICAL CONDITION.  1. Wash and clean trailer if required.  2. Observe condition of paint and legibility of markings and plates.	
17	A	INSPECT AIR TANKS.  Drain air after each operation.	

**Section III. OPERATION UNDER USUAL CONDITIONS**

**2.3.1 ASSEMBLY AND PREPARATION FOR USE**

1. Perform preventive maintenance checks and services as specified in Table 2-1.
2. Be sure that front supports (landing gear) are down.
3. Move crank handles from stowed position and raise leveling jacks to full up position. Stow handles.

**CAUTION**

BE SURE VOLTAGE CONTROL UNIT OUTPUT CABLE IS PLUGGED INTO CHASSIS ELECTRICAL CONNECTION BEFORE PROCEEDING.

4. Back tractor into position ensuring that fifth wheel fully engages and locks trailer king pin.
5. Raise landing gear to full up position and store crank handle.
6. If tractor has 24 Vdc electrical interconnect power cable, proceed as follows:

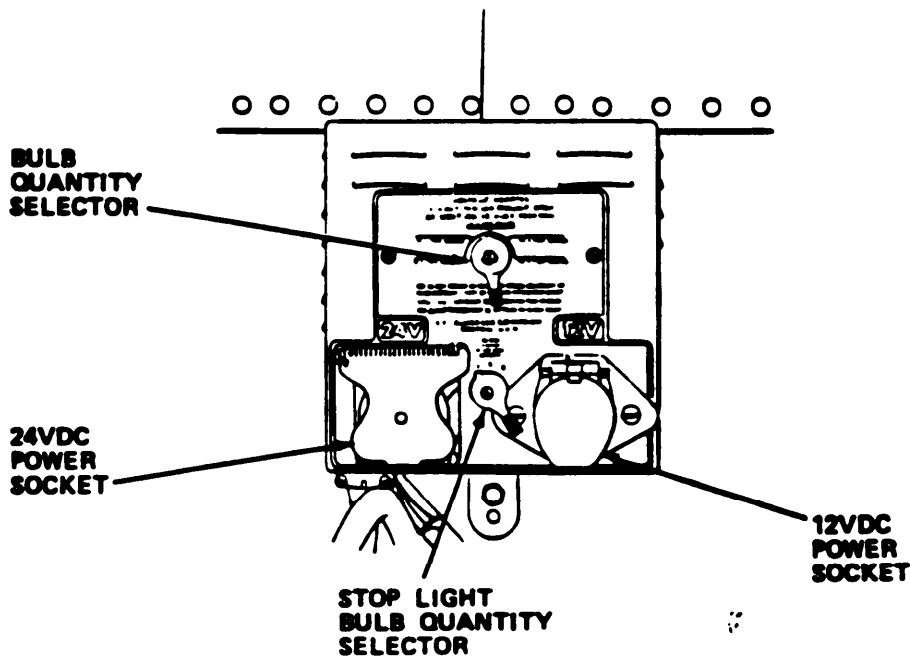

- Place voltage control unit bulb quantity selector to 16-12 V bulb position.

- Place stop light bulb quantity selector to position 2.
  - Plug tractor interconnect cable into 24 Vdc socket.
7. If standard 12 Vdc power interconnect cable is used, plug into 12 Vdc socket.
  8. Connect tractor interconnect service (yellow gladhand) and emergency (red gladhand) air lines to mating gladhands on trailer.
  9. If auxiliary tow vehicle is to be attached, proceed as follows:

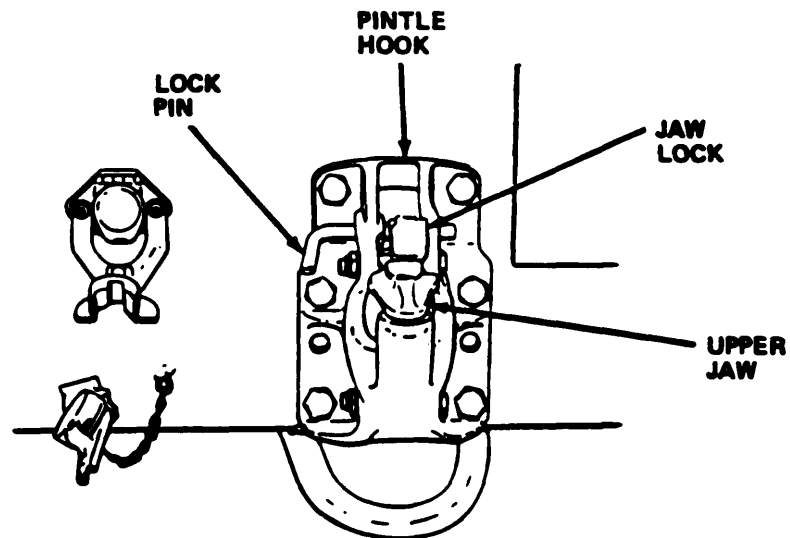

- Pull out on pintle hook spring-loaded lock pin and raise upper jaw.
- Position tow vehicle drawbar in pintle hook and hook up safety chains.

**WARNING**

BE SURE THAT UPPER JAW IS PROPERLY  
LOCKED TO PREVENT TRAILER FROM  
COMING LOOSE DURING TRANSPORT.

- Close upper jaw and be sure that it does lock.
- Connect tow vehicle power interconnect cable to trailer seven-contact receptacle.
- Connect tow vehicle interconnect service (yellow gladhand) and emergency (red gladhand) air lines to mating gladhands on trailer (if used).

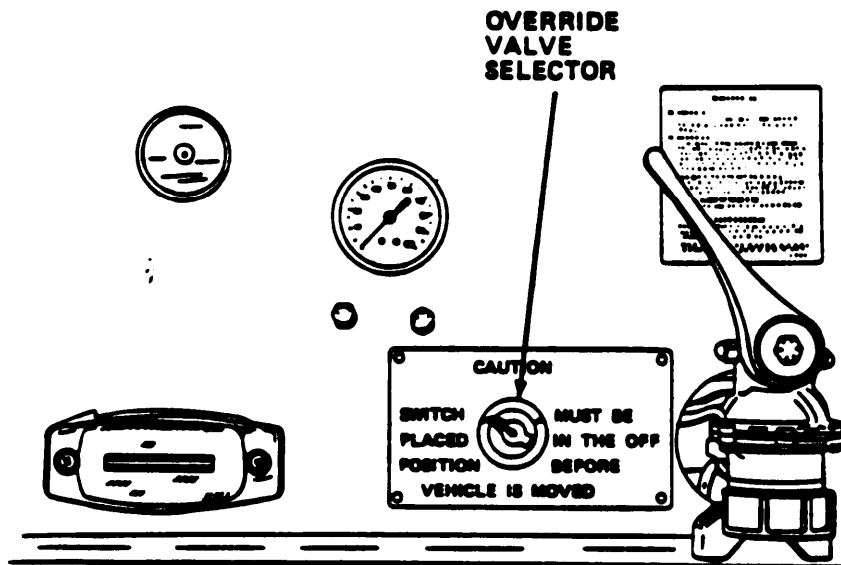

10. Be sure that override valve selector is in OFF position allowing air ride bags to lift load to preset height.
11. Test brakes on trailer and tow vehicle (as applicable) by observing brake valve action at all wheels.
12. Test for proper operation of clearance marker, license, tail, stop, turn signal and emergency flasher lights on trailer and tow vehicle (as applicable).
13. Be sure van body-to-trailer corner locks are locked.

### 2.3.2 PARKING

1. Park trailer on a firm, fairly level, well drained surface.
2. Move crank handle from stowed position and engage with front support (landing gear) gearbox.
3. Lower landing gear to ground.
4. Disconnect service and emergency interconnect air lines from trailer at gladhands and stow lines.
5. Disconnect tractor's interconnect power lead from trailer voltage control unit receptacle. **Stow lead.**
6. Unlock fifth wheel to trailer king pin and detach tractor from trailer.
7. Place override valve selector to ON.

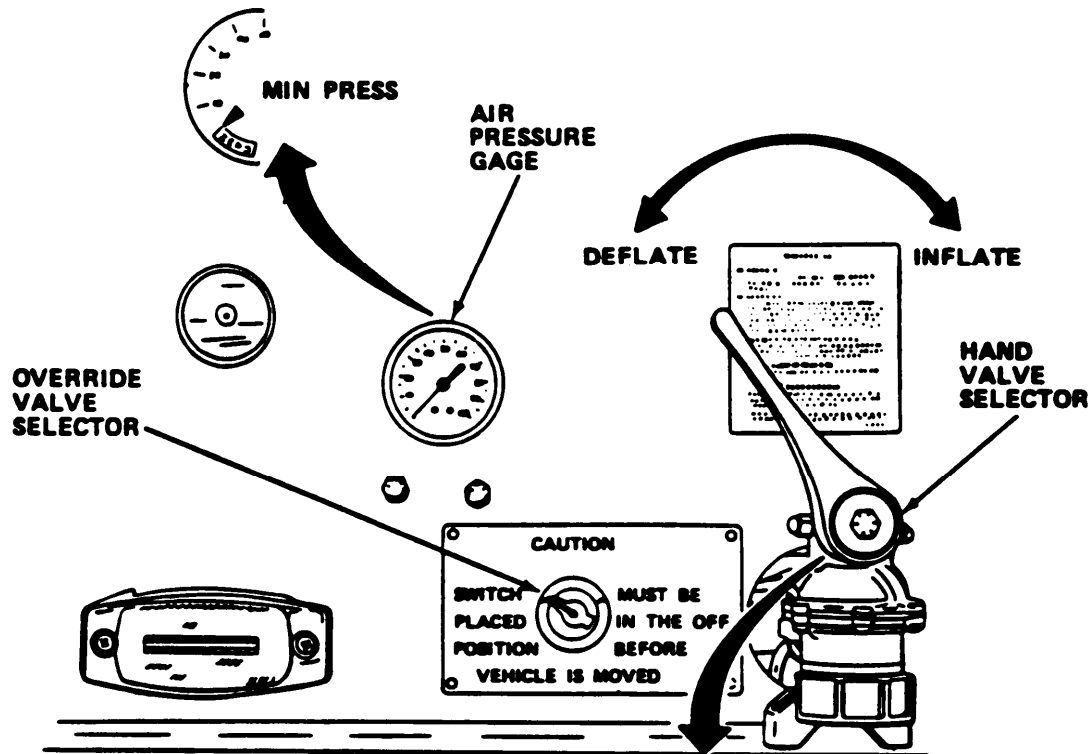

DO NOT REDUCE PRESSURE TO LESS THAN 3 PSI TO PREVENT AIR BAG FROM CREAMING.

8. Move override hand valve lever to deflate position and bleed air ride system to 3 psi as seen on system pressure gage.
9. Move override valve selector to OFF.
10. If auxiliary tow vehicle is attached, proceed as follows:
  - Disconnect service and emergency interconnect lines from trailer at gl adhands (i nappi cabl e).
  - Disconnect interconnect power lead from trailer seven-contact power receptacle. Stow lead.
  - Pull out on pintle hook spring-loaded lock pin and raise upper jaw.
  - Detach tow vehicle from trailer.
  - Close pintle hook upper jaw.

11. If van body requires leveling, proceed as follows:

- Move crank handle from stowed position and lower leveling jacks to ground.
- Using van body level indicators, adjust jacks to level load from front to rear and side to side.

12. Stow jacks crank handles.

**2.3.3 OPERATING INSTRUCTIONS AND DECALS**

**2.3.3.1 VOLTAGE CONTROL UNIT INSTRUCTION PLATE ON FRONT OF VOLTAGE CONTROL UNIT**

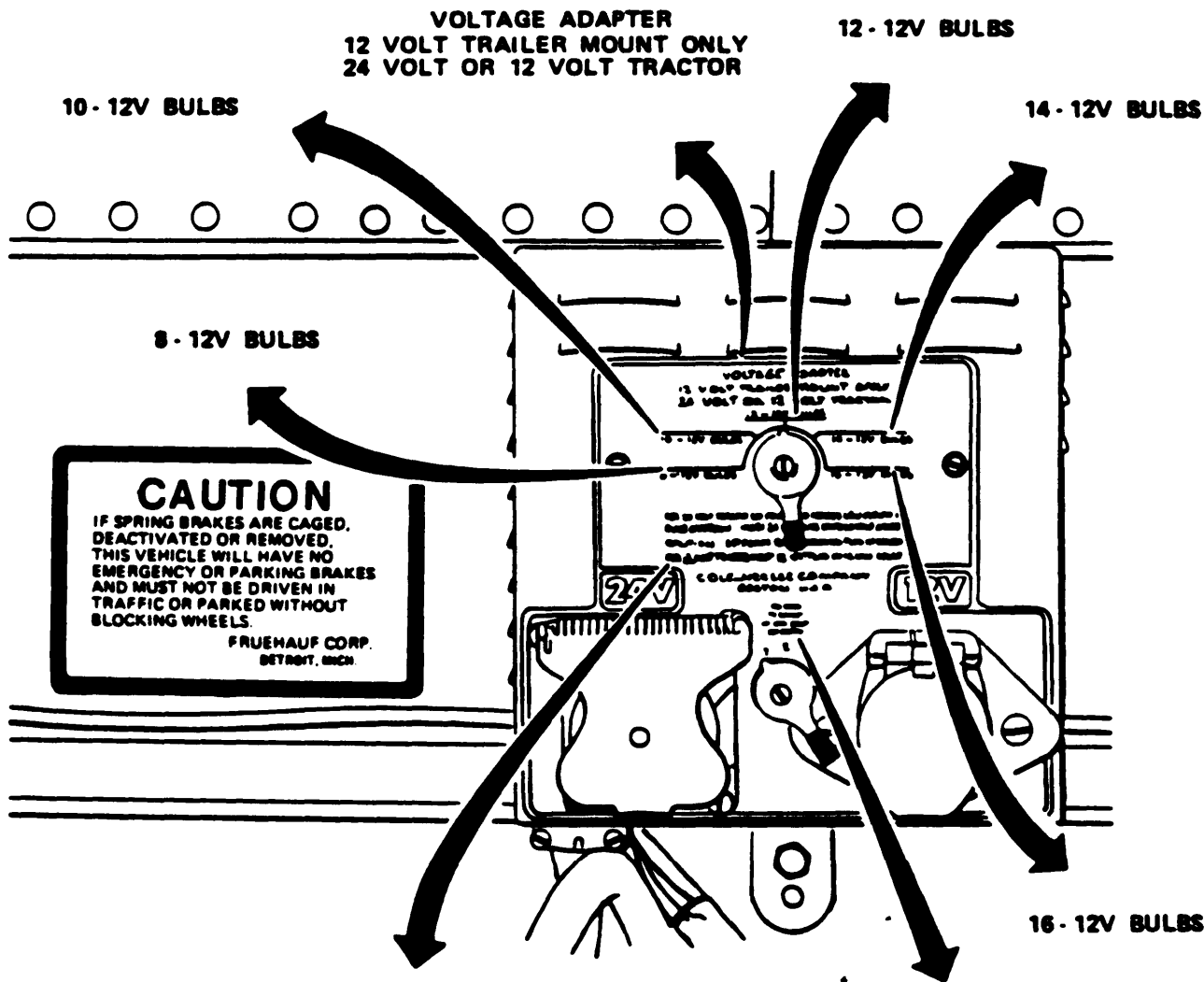

**FOR 24 VOLT TRACTOR SET POINTER TO NEAREST LOW NUMBER OF BULBS ON TRAILER. INSERT 24 VOLT PLUG INTO 24 VOLT SOCKET. CAUTION: SET POINTER BEFORE INSERTING PLUG IN SOCKET. FOR 12 VOLT TRACTOR INSERT 12 VOLT PLUG IN 12 VOLT SOCKET.**

**SET LEVER TO NUMBER OF STOP LAMPS ON TRAILER**



2.3.3.2 CAUTION DECAL NEXT TO VOLTAGE CONTROL UNIT

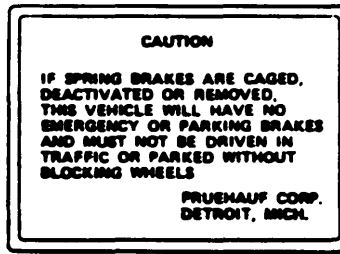

2.3.3.3 OVERRIDE SELECTOR SWITCH DECAL

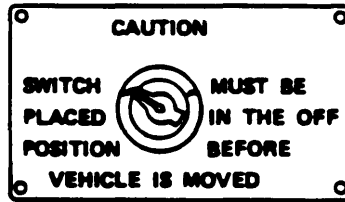

2.3.3.4 HAND VALVE DECAL

**OPERATING INSTRUCTIONS**  
Neway Air Suspension with Manual Control

1. **EMPTY OPERATION**  
To deflate air springs, turn handle to exhaust position. **CAUTION:** Do not operate unit without air minimum pressure to be approximately 3 PSI.
2. **LOADED OPERATION**  
To inflate air springs, move handle to inflate position until desired pressure is obtained. (Approximately 65 PSI for a 16000 lb. load at dead axle.) Hand valve will maintain set pressure for desired axle load distribution, calibrate air gaps by seating axle weights and checking air pressure. **CAUTION:** Do not operate loaded vehicle without proper amount of air pressure.
3. **TRACTION CONTROL OPERATION (TRACTORS & TRUCKS)**  
Move handle to lower pressure position until desired traction is obtained. By reducing air pressure at dead axle, load will be transferred to drive axle. **CAUTION:** Do not overload drive axle.
4. **COUPLING TO LOADED TRAILER (TRACTOR)**  
Inflate air springs to a higher pressure but maintain proper traction.

**ADJUSTING INSTRUCTIONS**

**MINIMUM PRESSURE SETTING ADJUSTMENT** - Set hand valve to minimum desired pressure, then tighten upper screw nut securely. Minimum pressure not to be less than 3 PSI.

**MAXIMUM PRESSURE SETTING ADJUSTMENT** - Set hand valve to maximum desired pressure, then tighten lower screw nut securely.

90044021 3/776

2.3.3.5 ELECTRICAL SCHEMATIC

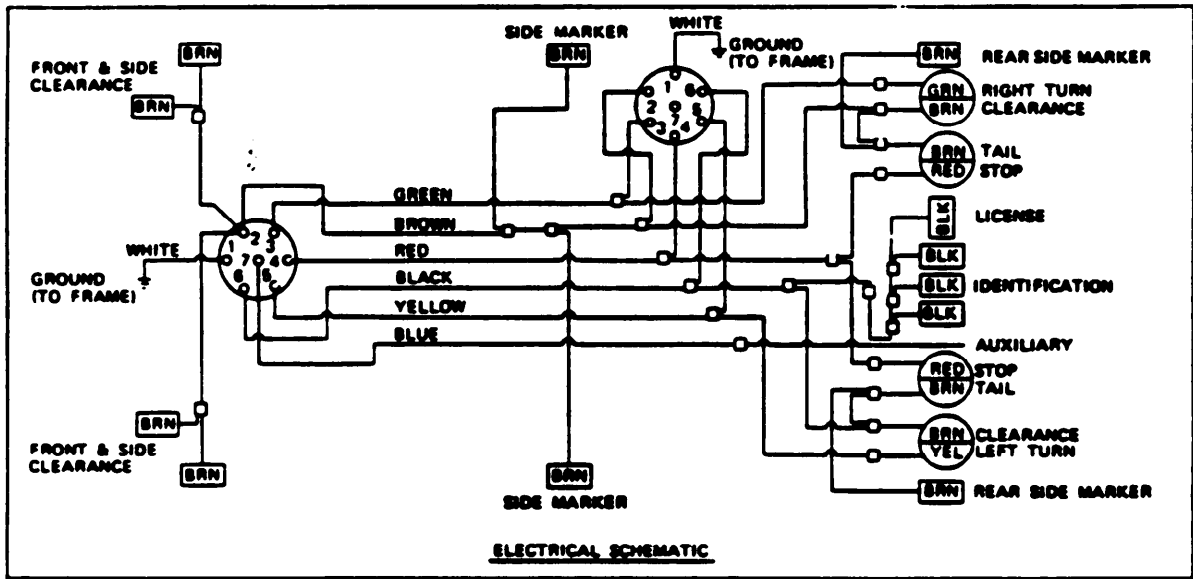

## Section IV. OPERATION UNDER UNUSUAL CONDITIONS

**2.4.1 OPERATION IN COLD WEATHER.** Extremely cold weather creates hardening of air lines and electrical leads. Caution should be taken not to disturb any lines or leads to prevent permanent damage. Air tanks must be drained of moisture at increased intervals. Lubrication intervals must also be increased. Tire pressure should be frequently checked.

**2.4.2 OPERATION IN EXTREME HEAT.** Extreme heat can create excessive tire pressures and wear. Tire conditions and pressures should be checked at increased intervals. Lubricants tend to thin out and dry out sooner creating undue wear of moving parts. Lubrication intervals must be increased. Sustained high temperatures can accelerate deterioration of pneumatic systems' seals, requiring closer attention to leaks and erratic operation.

**2.4.3 OPERATION IN DUSTY AND SANDY AREAS.** Dust, dirt and sand are abrasives which accelerate moving parts, deterioration. Frequent cleaning and hosing should be accomplished. Increased lubrication frequencies are a must to preclude failures.

**2.4.4 FORDING.** No special procedures are required before fording. Caution must be taken when applying brakes during and after fording. Wet brake lining can prevent normal brake response.



## CHAPTER 3

### OPERATOR/CREW MAINTENANCE INSTRUCTIONS

#### Section I. LUBRICATION INSTRUCTIONS

**3.1.1 LUBRICATION INSTRUCTIONS.** Lubrication instructions are covered in LO 5-2330-305-12.

#### Section II. TROUBLESHOOTING

**3.2.1 INTRODUCTION.** There are no specific troubleshooting procedures to be followed by trailer operating personnel. While the trailer is being operated on the road or when parked, the operator should constantly observe the various portions and assemblies of the trailer for erratic operation or possible malfunctions. Erratic operation or apparent malfunctions should be reported to the appropriate maintenance personnel as they occur.

#### **CAUTION**

IF ANY OPERATING CONTROLS APPEAR "SLUGGISH" OR DIFFICULT TO MANIPULATE DURING NORMAL OPERATION, DO NOT ATTEMPT TO FORCE THEM TO OPERATE. STOP OPERATION AND NOTIFY MAINTENANCE PERSONNEL.

### Section III. MAINTENANCE PROCEDURES

**3.3.1 MAINTENANCE PROCEDURES** This section contains the step-by-step procedures for performing Operator's maintenance for the Chassis, Semi trailer. Personnel required are listed only if the task requires more than one. If personnel are not listed, it means one person can do the task.

#### INDEX

PROCEDURE	PARAGRAPH
Replace License Plate Light . . . . .	3.3.1.1
Replace Clearance, Marker, and Identification Lights . . . . .	3.3.1.2
Replace Stoplights, Turn Signals, and Tail Lights . . . . .	3.3.1.3

#### **3.3.1.1 REPLACE LICENSE PLATE LIGHT.**

TOOLS: Flat-Tipped Screwdriver

SUPPLIES: Light

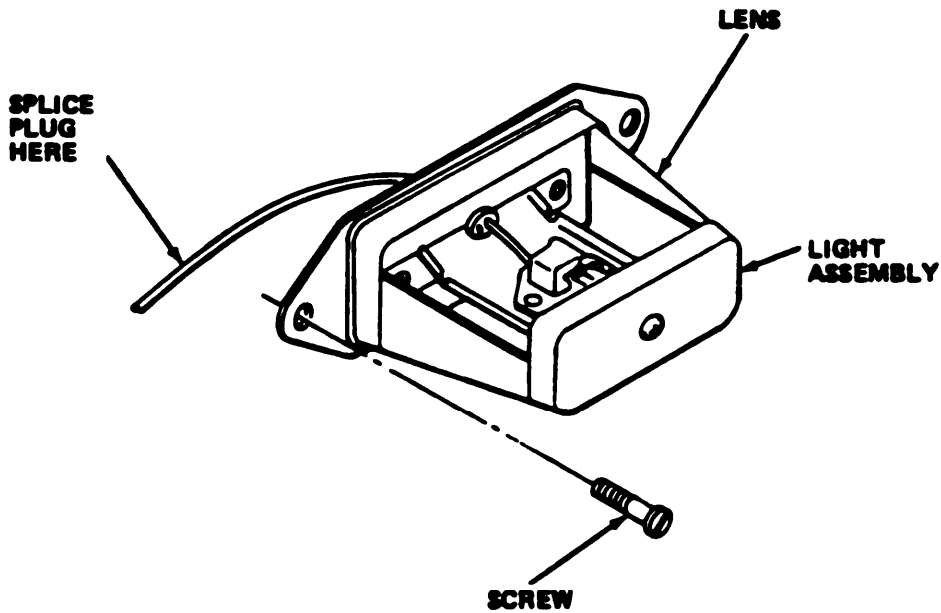

1. Remove from frame by removing two machine screws.
2. Unwrap tape and locate connections.
3. Disconnect plug from receptacle.
4. Remove light assembly.

**NOTE**

Replacement license plate lights do not have a plug connector. Mounting holes will have to be drilled out to match machined holes in frame.

5. Clip plug from old light and splice to replacement light, or attach new plug to replacement light.
6. Wrap with tape.
7. Push plug through hole in chassis.
8. Connect plug and receptacle.
9. Wrap with tape.
10. Attach light assembly to frame with two machine screws.

**3.3.1.2 REPLACE CLEARANCE, MARKER, AND IDENTIFICATION LIGHTS.**

TOOLS: Flat-Tipped Screwdriver

SUPPLIES: Light

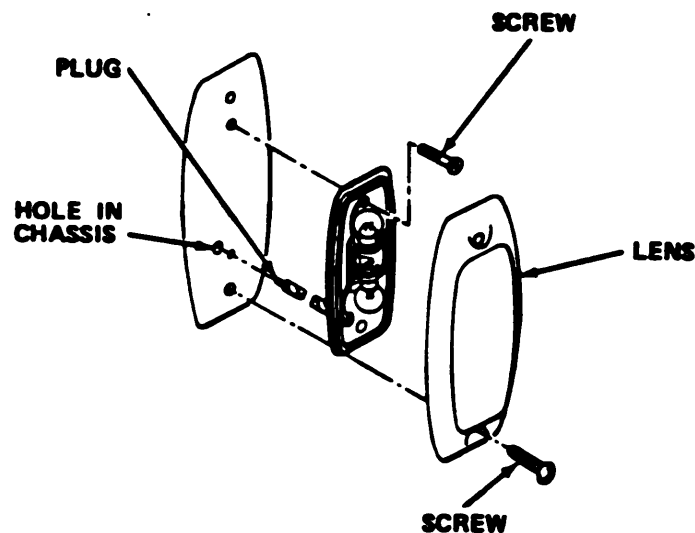

1. Remove lens by removing two sheet metal screws.
2. Remove light assembly from frame by removing two machine screws.

3. Unwrap tape and locate connections.
4. Disconnect plug from receptacle.
5. Remove light assembly.
6. Push plug through hole in chassis.
7. Connect plug and receptacle.
8. Wrap with tape.
9. Attach light assembly to frame with two machine screws.
10. Reinstall lens with two sheet metal screws.

**3.3.1.3 REPLACE STOP LIGHTS, TURN SIGNALS, AND TAIL LIGHTS.**

SUPPLIES: Bulb

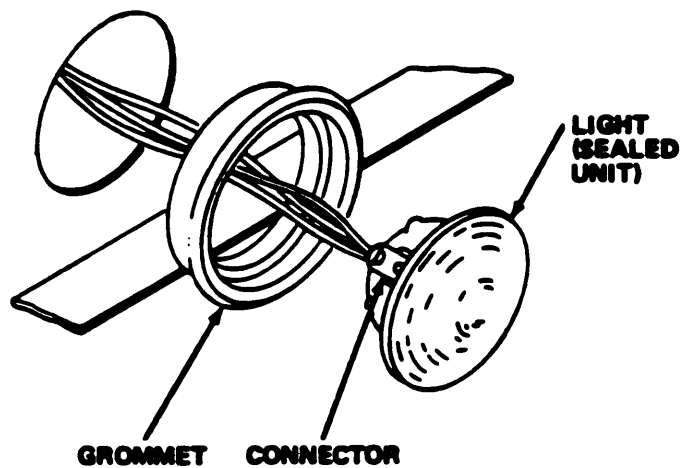

1. Press light and grommet in.
2. Remove light and grommet.
3. Disconnect inoperable light.
4. Reconnect replacement light.
5. Reinstall grommet.
6. Spray grommet with silicone spray to lubricate.
7. Press light firmly into grommet.



**CHAPTER 4****ORGANIZATIONAL MAINTENANCE INSTRUCTIONS****Section I. REPAIR PARTS, SPECIAL TOOLS AND EQUIPMENT**

**4.1.1 COMMON TOOLS AND EQUIPMENT** For authorized common tools and equipment, refer to the Modified Table of Organization and Equipment (MTOE) applicable to your unit.

**4.1.2 SPECIAL TOOLS; TEST, MEASUREMENT AND DIAGNOSTIC EQUIPMENT; AND SUPPORT EQUIPMENT** No special tools; test, measurement, and diagnostic equipment; or support equipment are required for the repair of this equipment at the Organizational level of maintenance.

**4.1.3 REPAIR PARTS** Repair parts for this equipment are listed in the Repair Parts and Special Tools List (RPSTL), TM 5-2330-305-24P covering Organizational and Direct/General Support maintenance.

**Section II. ORGANIZATIONAL PREVENTIVE MAINTENANCE CHECKS AND SERVICES****4.2.1 INTRODUCTION**

- a. Always keep in mind the WARNINGS and CAUTIONS when performing PMCS. Table 4-1 lists the PMCS procedures to be performed by Organizational maintenance. Be sure to perform the PMCS at the frequency indicated by the INTERVAL codes in the table.
- b. If your equipment fails to operate, troubleshoot with the proper equipment. Report any deficiencies in accordance with TM 38-750.

**NOTE**

If the equipment must be kept in continuous operation, check and service only those items that can be checked and serviced without disturbing operation. Make the complete checks and services when the equipment can be shut down.

- c. The numbers found in the ITEM NUMBER column shall be used as a source of item numbers for the TM NUMBER column on DA Form 2404, Equipment Inspection and Maintenance Worksheet, in recording the results of PMCS

d. List of tools and materials required for PMCS is as follows:

Item	Quantity
Liquid Detergent	1 ea
Plastic Pail	1 ea
Socket (1 1/2 in.)	1 ea
Torque Wrench	1 ea

Table 4-1. ORGANIZATIONAL PREVENTIVE MAINTENANCE CHECKS AND SERVICES

**B - Before**                      **W - Weekly**                      **AN - Annually**                      **(Number) - Hundreds of Hours**  
**D - During**                      **M - Monthly**                      **S - Semiannually**  
**A - After**                      **Q - Quarterly**                      **BI - Biannually**

Item No.	INTER-VAL	ITEM TO BE INSPECTED
		PROCEDURE
1	M	INSPECT LEVELING JACK. Inspect jack for structural damage and proper operation. <b>ensure legs will extend</b> and retract the full extent of their travel with no binding noted.
2	M	INSPECT AXLE ASSEMBLY. Inspect axle assembly for structural damage, cracks in welds, excessive wear and proper operation of brakes.
3	M	INSPECT AIR RIDE ASSEMBLY. 1. Check for loose or missing bolts, nuts, etc. 2. Check fittings for leaks by applying a soapy <b>water solution and inspecting for presence of bubbles.</b>

Table 4-1. ORGANIZATIONAL PREVENTIVE MAINTENANCE CHECKS AND SERVICES (Cont)

B - Before  
D - During  
A - After

W - Weekly  
M - Monthly  
Q - Quarterly

AN - Annually  
S - Semiannually  
BI - Biannually

(Number) - Hundreds of Hours

ITEM NO.	INTERVAL	ITEM TO BE INSPECTED  PROCEDURE
4	M	<p data-bbox="354 562 568 594">INSPECT HITCH.</p> <div data-bbox="511 646 1071 1087" style="text-align: center;">  </div> <ol data-bbox="370 1165 1214 1234" style="list-style-type: none"> <li>1. Check for loose bolts or nuts. Tighten if necessary.</li> </ol> <div data-bbox="451 1243 1172 1633" style="text-align: center;">  </div> <ol data-bbox="370 1711 1221 1900" style="list-style-type: none"> <li>2. Check hoses and relay valves for leaks with soapy water solution.</li> <li>3. Check shutoff valve for proper operation.</li> <li>4. Check backslap valve for proper operation.</li> </ol>

Table 4-1. ORGANIZATIONAL PREVENTIVE MAINTENANCE CHECKS AND SERVICES (Cont)

B - Before                      W - Weekly                      AN - Annually                      (Number) - Hundreds of Hours  
 D - During                      M - Monthly                      S - Semiannually  
 A - After                      Q - Quarterly                      BI - Biannually

ITEM NO.	INTERVAL	ITEM TO BE INSPECTED  PROCEDURE
5	M	<p data-bbox="297 451 718 493">INSPECT OVERRIDE ASSEMBLY.</p>  <ol data-bbox="297 1386 1172 1858" style="list-style-type: none"> <li>1. Inspect override assembly for loose or missing nuts, bolts or fittings.</li> <li>2. Check hand and manual valves for proper operation. Replace if defective.</li> <li>3. Check gage for broken or missing lens. Replace gage if defective.</li> <li>4. Check hoses and fittings for leaks by applying a soapy water solution and inspecting for bubbles.</li> </ol>

Table 4-1. ORGANIZATIONAL PREVENTIVE MAINTENANCE CHECKS AND SERVICES (Cont)

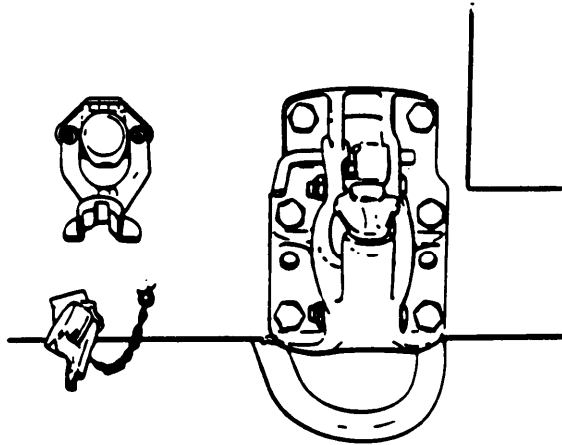
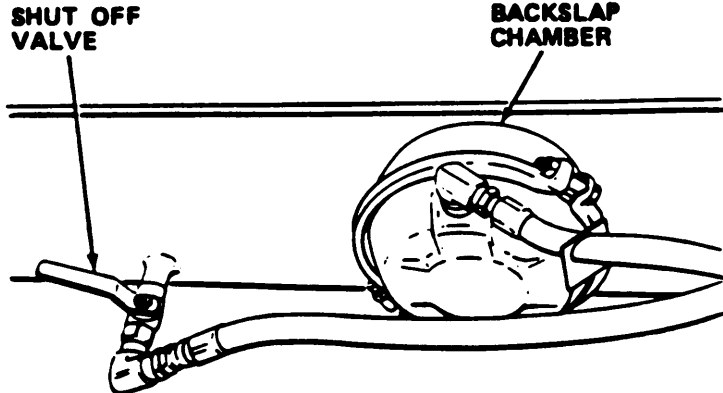
B - Before                      W - Weekly                      AN - Annually                      (Number) - Hundreds of Hours  
 D - During                      M - Monthly                      S - Semiannually  
 A - After                      Q - Quarterly                      BI - Biannually

ITEM NO.	INTERVAL	ITEM TO BE INSPECTED  PROCEDURE
6	Q	<p>INSPECT U-BOLTS.</p>  <p>The diagram shows a rear axle assembly. Labels with arrows point to the following components: AIR SPRING (top right), TRAILING ARM (middle right), AXLE (top left), BRAKE VALVE (REF) (middle left), SHOCK ABSORBER (bottom left), and U-BOLTS (bottom center).</p> <ol style="list-style-type: none"> <li>1. Inspect U-bolts for rust and wear.</li> <li>2. Alternately retorque U-bolt nuts until 700-750 ft lbs is achieved.</li> </ol>

**Section III. ORGANIZATIONAL TROUBLESHOOTING**

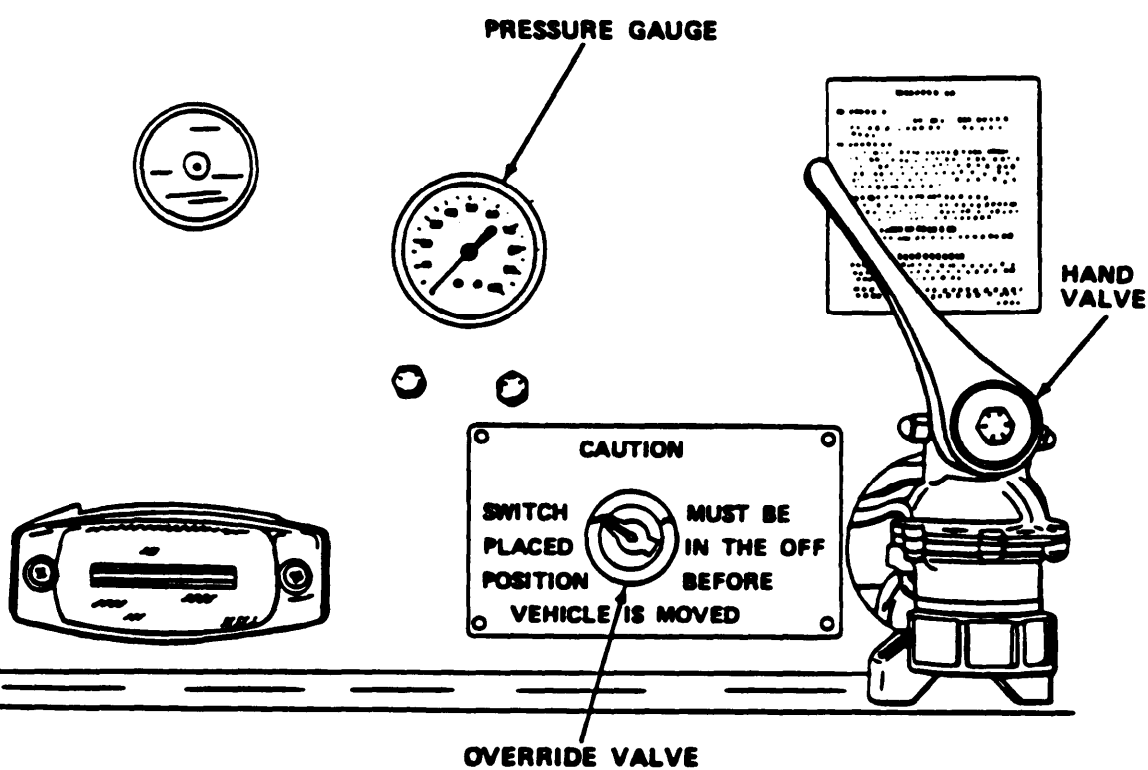
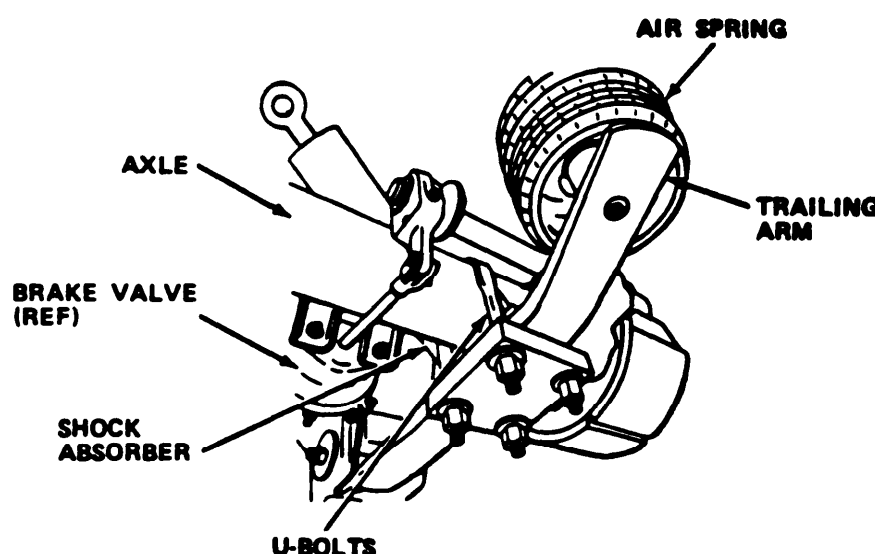
**4.3.1 INTRODUCTION**

a. Organizational troubleshooting procedures cover the most common malfunctions that may be repaired at the Organizational level. Repair or adjustment requiring specialized equipment is not authorized unless such equipment is available. Troubleshooting procedure used by the operator should be conducted in addition to the Organizational Troubleshooting procedures.

b. THIS MANUAL CANNOT LIST ALL THE POSSIBLE MALFUNCTIONS OR EVERY POSSIBLE TEST/ INSPECTION AND CORRECTIVE ACTION. IF A MALFUNCTION IS NOT LISTED OR CORRECTED BY A LISTED CORRECTIVE ACTION, NOTIFY YOUR SUPERVISOR.

**Table 4-2 ORGANIZATIONAL TROUBLESHOOTING**

---

MALFUNCTION	TEST OR INSPECTION/PROBABLE CAUSE	CORRECTIVE ACTION
-------------	-----------------------------------	-------------------

---

1. BRAKES WILL NOT RELEASE.

Step 1. Check to see if brake shoes are bound up at anchor pins.

Lubricate brake operating parts.

Step 2. Check to see if brake hoses are restricted.

Replace brake hoses as applicable. (4.4.1.4)

Step 3. Check to see if brakes are out of adjustment.

Adjust brakes as necessary. (4.4.1.21)

2. NO BRAKES OR INSUFFICIENT BRAKES.

Step 1. Check to see if the source of the air supply is shut off at the tractor.

Open cutout cocks at rear of tractor cab or push control valve in.

Step 2. Check to see if brake lines between tractor and trailer are properly coupled.

Properly couple brake lines between tractor and Trailer.

**Table 4-2 ORGANIZATIONAL TROUBLESHOOTING (Cont)**

## MALFUNCTION

TEST OR INSPECTION/PROBABLE CAUSE

CORRECTIVE ACTION

3. WOBBLY TIRES.

Step 1. Check to see if tire wobble is due to uneven rim clamping.

Torque-tighten all rim clamps. (4.4.1.1)

Step 2. Check to see if any of the wheels or rims are bent.

Replace bent wheel or rim. (4.4.1.1)

4. LOSS OF TIRE AIR PRESSURE.

Step 1. Check to see if the tire has been punctured.

Replace or repair punctured tire.

Step 2. Check to see if the tire has a faulty valve or valve core.

Replace valve assembly or core.

Step 3. Check to see if the wheel or rim have been damaged.

Replace damaged wheel or rim. (4.4.1.1)

5. EXCESSIVE OR UNEVEN TIRE WEAR.

Step 1. Check tire pressure to see if it is overinflated or underinflated.

Inflate the tire to the proper pressure of 85 psi.

Step 2. Check to see if there are loose wheel stud nuts or clamps.

Tighten wheel stud nuts or clamps.

Step 3. Check to see if there are loose or tight wheel bearing adjustments.

Adjust bearings as applicable. (Refer to Direct/General Support Maintenance.)

Step 4. Check to see if the tires are properly matched.

Match the tires.

**Table 4-2 ORGANIZATIONAL TROUBLESHOOTING (Cont)**

MALFUNCTION	TEST OR INSPECTION/PROBABLE CAUSE	CORRECTIVE ACTION
5. (Cont)		
	Step 5. Check to see if the trailer has been driven in a manner which included rapid stopping.	When approaching a stop, apply the brakes slowly.
	Step 6. Check to see if the trailer has been driven in a manner which included high speed driving on turns.	Reduce speed when traveling on turns.
6. <u>SCUFFED TIRES.</u>		
	Step 1. Check the tire pressure to see if it is overinflated or underinflated.	Inflate the tire to the proper pressure of 85 psi.
	Step 2. Check to see if the trailer has been driven in a manner which included excessive speed on turns.	Reduce speed when traveling on turns.
7. <u>GRABBING BRAKES.</u>		
	Step 1. Check to see if brakes are out of adjustment.	Adjust brakes as necessary. (4.4.1.21)
	Step 2. Check to see if there is a damaged brake chamber or internal assembly.	Notify Direct/General Support Maintenance personnel of trouble.
	Step 3. Check to see if there is a leaky or broken hose between the relay valve and the brake chamber.	Repair or replace the defective hose as applicable.



**Table 4-2. ORGANIZATIONAL TROUBLESHOOTING (Cont)**

MALFUNCTION	TEST OR INSPECTION/PROBABLE CAUSE	CORRECTIVE ACTION
8. <u>BRAKES DRAGGING.</u>	Step 1. Check to see if brakes are out of adjustment.	Adjust brakes as necessary. (4.4.1.21)
	Step 2. Check to see if there is a binding cam, anchor pins or chamber rod end pin.	Lubricate as necessary and free up binding parts.
9. <u>SLOW BRAKE APPLICATION OR RELEASE.</u>	Step 1. Check to see if the brake operating parts are adequately lubricated.	Lubricate the operating parts of the brake.
	Step 2. Check to see if there is any restriction in the brake hoses or lines.	Repair or replace defective hoses or lines as applicable. (4.4.1.4)
	Step 3. Check to see if brakes are out of adjustment.	Adjust brakes as necessary. (4.4.1.21)
	NOTE	
	<ul style="list-style-type: none"> <li>● A malfunction of the air suspension system will not necessarily be a cause for highway stoppage. Careful operation of the trailer will permit limited continued operation.</li> <li>● Rubber bumpers within each air spring are provided to carry the load in the event of an-air spring malfunction where deflation occurs.</li> </ul>	
10. <u>ALL AIR SPRINGS FLAT.</u>	Step 1. Check to see if the air supply is sufficient and check couplings and valve controls from the tractor to the Semi trailer with a soapy solution.	Build up and maintain the tractor air pressure to at least 85 psi. Repair or replace any defective couplings and valve controls as necessary. (4.4.1.4)

Table 4-2. ORGANIZATIONAL TROUBLESHOOTING (Cont)

MALFUNCTION	TEST OR INSPECTION/PROBABLE CAUSE	CORRECTIVE ACTION
(Cont)		
Step 2.	Inspect and test to see if there is a leak or broken air line in the trailer or air suspension system.	Locate the leak and/or broken air line and repair/replace as applicable. (4.4.1.4)
Step 3.	Check to see if height control valve is leaking.	Replace height control valve (4.4.1.23).
11. SUSPENSION DEFLATES RAPIDLY WHEN PARKED.		
Step 1.	Check to see if there is a leak in the air system.	Locate and repair the leak(s) in the air system.
12. AIR SPRINGS WORN EXCESSIVELY.		
Step 1.	Check to see if the worn air spring is contacting or rubbing the frame, tires or rims. If there is contact or rubbing, check for proper tire sizes, clearances and inflation.	Replace tires that are incorrect size. Inflate tires to the correct pressure of 85 psi and remove any obstacle that may prevent the tires from having the proper clearance.
Step 2.	Check to see if the air springs are being operated without air pressure in the spring.	Refer to the corrective action for Malfunction 10.
Step 3.	Check to see if the air suspension system is, being operated before allowing adequate time for the pressure to build up.	Refer to the corrective action for Malfunction 10.

**Section IV. MAINTENANCE PROCEDURES**

**4.4.1 MAINTENANCE PROCEDURES** This section contains the step-by-step procedures for performing Organizational maintenance for the Chassis, Semi trailer. Personnel required are listed only if the task requires more than one. If personnel are not listed, it means one person can do the task.

INDEX

PROCEDURES	PARAGRAPH
Repl ace Ti res. . . . .	4. 4. 1. 1
Repl ace Rati o Rel ay Val ve. . . . .	4. 4. 1. 2
Repl ace Rel ay Qui ck Rel ease Val ve . . . . .	4. 4. 1. 3
Repl ace Ai r Hose . . . . .	4. 4. 1. 4
Repl ace Brake Chamber. . . . .	4. 4. 1. 5
Repl ace Overri de Val ve Sel ector . . . . .	4. 4. 1. 6
Repl ace Pi lot Val ve. . . . .	4. 4. 1. 7
Repl ace Hand Lever Val ve . . . . .	4. 4. 1. 8
Repl ace Gage . . . . .	4. 4. 1. 9
Repl ace Landi ng Gear Assembl y . . . . .	4. 4. 1. 10
Repl ace Back Sl ap Chamber . . . . .	4. 4. 1. 11
Repl ace Auxi li ary Servi ce Rel ay . . . . .	4. 4. 1. 12
Repl ace Hi tch Shutoff Val ve . . . . .	4. 4. 1. 13
Repl ace Ai r Spri ng . . . . .	4. 4. 1. 14
Repl ace Repl ace Shock Absorber. . . . .	4. 4. 1. 15
Repl ace Equal i zer Bushi ng . . . . .	4. 4. 1. 16
Repl ace U-Bol ts. . . . .	4. 4. 1. 17
Repl ace Moi sture Ejector . . . . .	4. 4. 1. 18
Repl ace Refl ector. . . . .	4. 4. 1. 19
Repl ace Vol tage Control Uni t. . . . .	4. 4. 1. 20
Ini ti al Brake Adj ustment . . . . .	4. 4. 1. 21

PROCEDURES	PARAGRAPH
Replace Leveling Jack . . . . .	4. 4. 1. 22
Adjust Height Control . . . . .	4. 4. 1. 23
Replace Height Control Valve. . . . .	4. 4. 1. 24
Replace Air Hoses . . . . .	4. 4. 1. 25
Replace Hubdomter . . . . .	4. 4. 1. 26

4. 401. 1 REPLACE TIRE.

- TOOLS: Socket  
 Breaker Bar  
 Extension Bar  
 Torque Wrench

SUPPLIES: Tire

**CAUTION**

USE ONLY TIRE SIZES AND TYPES LISTED ON THE SAFETY AND SERIAL PLATE ATTACHED TO THE TRAILER.

USE ONLY WHEEL RIM WIDTHS AND OFFSETS LISTED THE SAFETY AND SERIAL PLATE ATTACHED TO THE TRAILER.

1. Loosen, but do not remove, ten wheel nuts.
2. Using leveling jacks, extend jack until tire is just clear of ground.
3. Remove ten wheel nuts.
4. Remove tire and wheel from axle.
5. Remove tire from wheel and repair or replace.
6. Reinstall tire to wheel and inflate to 85 psi maximum

**CAUTION**

TIRES MUST BE MATCHED. VALVES SHOULD ALL BE POINTED FORWARD. ROTATION SHOULD BE FRONT TO REAR ONLY.

7. Reinstall tire and wheel to axle.

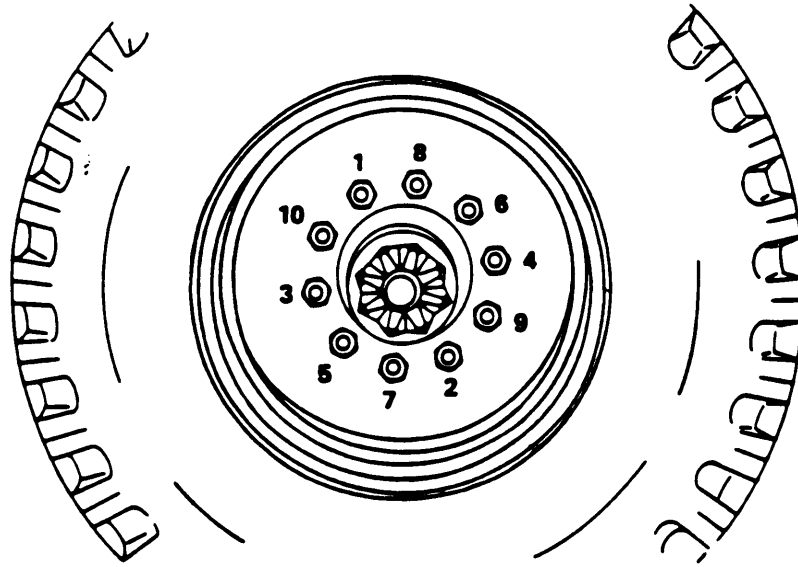

8. Reinstall ten wheel nuts to studs. Tighten alternately in sequence shown to 450-500 ft lbs (332-369 N•m) torque.
9. Raise leveling jacks slowly.
10. Operate chassis a short distance (approximately 50 miles) and check wheel nuts for tightness. Retorque where necessary.

4. 4. 1. 2 REPLACE RATIO RELAY VALVE.

TOOLS: Combination Wench Set

SUPPLIES: Ratio Relay Valve  
Thread Sealant (TFL)  
Liquid Detergent  
Plastic Pail  
Cotton Cloth  
Solvent

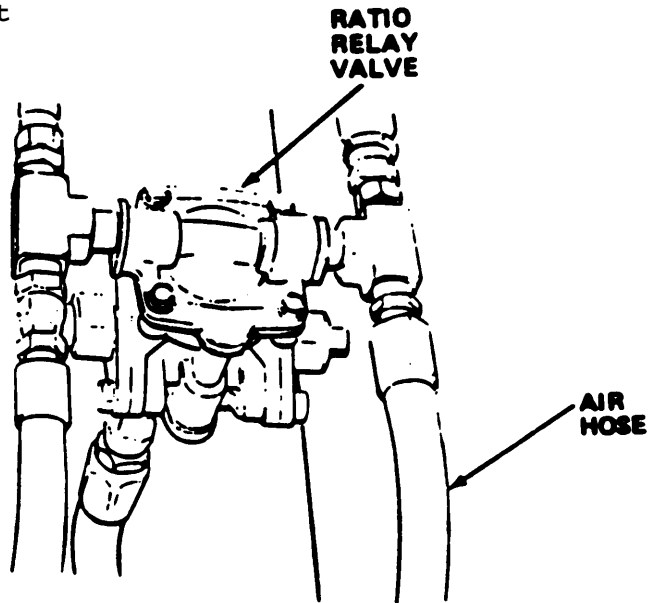

1. Re-pressurize system by opening moisture ejectors.
2. Loosen fittings and remove six air hoses.
3. Remove two T-fittings and couplings.
4. Remove two lower couplings from valve.
5. Remove relay valve from tank.
6. Clean fitting threads on new valve with a solvent-saturated, cotton cloth.
7. Coat threads with sealant and install new relay valve to tank.
8. Coat threads with sealant and reinstall T-fittings and couplings to tank.
9. Reinstall air hoses and tighten fittings securely.
10. Pressurize system with air.
11. Check for leaks by coating fittings with a soapy water solution and inspecting for the presence of bubbles.

4.4.1.3 REPLACE RELAY QUICK RELEASE VALVE.

TOOLS: Combination Wrench Set

SUPPLIES: Relay Quick Release Valve  
Thread-sealant (TFL)  
Liquid Detergent  
Plastic Pail  
Cotton Cloth  
Solvent

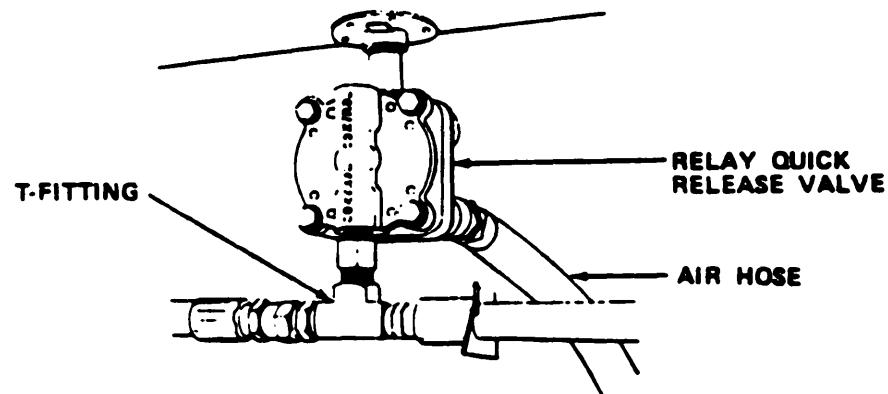

1. Repressurize system by opening moisture ejectors.
2. Loosen fittings and remove three air hoses.
3. Remove two T-fittings and couplings.
4. Remove lower coupling from valve.
5. Remove valve from tank.
6. Clean fitting threads on new valve with a solvent-saturated, cotton cloth.
7. Coat threads with sealant and install new relay valve to tank.
8. Coat threads with sealant and reinstall two lower couplings to valve.
9. Coat threads with sealant and reinstall T-fittings and couplings to tank.
10. Reinstall air hoses and tighten fittings securely.
11. Pressurize system with air.
12. Check for leaks by coating fittings with a soapy water solution and inspecting for the presence of bubbles.

4.4.1.4 REPLACE AIR HOSE.

TOOLS Combination Wrench Set

SUPPLIES: Hose

1. Repressurize air system.
2. Loosen both connectors and remove hose.
3. Remove tag from hose.
4. Reinstall tag to new hose.
5. Install new hose and tighten connectors.
6. Pressurize air system.
7. Check for air leaks by coating fittings with soapy water solution and inspection for presence of bubbles.

4.4.1.5 REPLACE BRAKE CHAMBER.

TOOLS: Combination Wrench Set  
Pliers

SUPPLIES: Brake Chamber

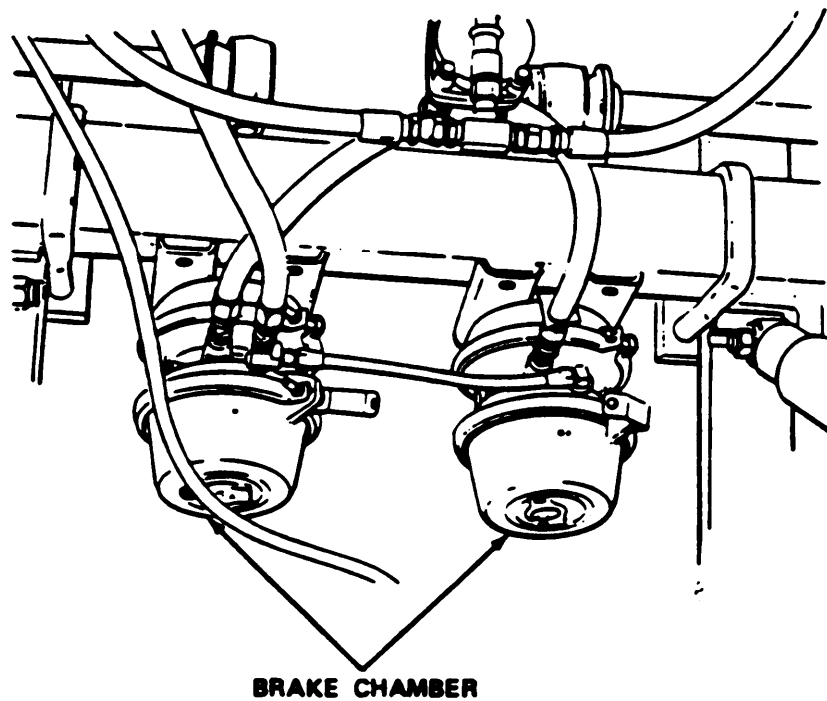

1. Depressurize system by opening moisture ejectors.



**NOTE**

Male pipe end of air hose does not swivel. To remove the male end of an air hose from a component, disconnect the swivel at the other end of the air line. Then disconnect the air line from the chassis so that the male pipe end turns freely.

2. Loosen connectors and remove air hoses.
3. Remove cap from chamber.

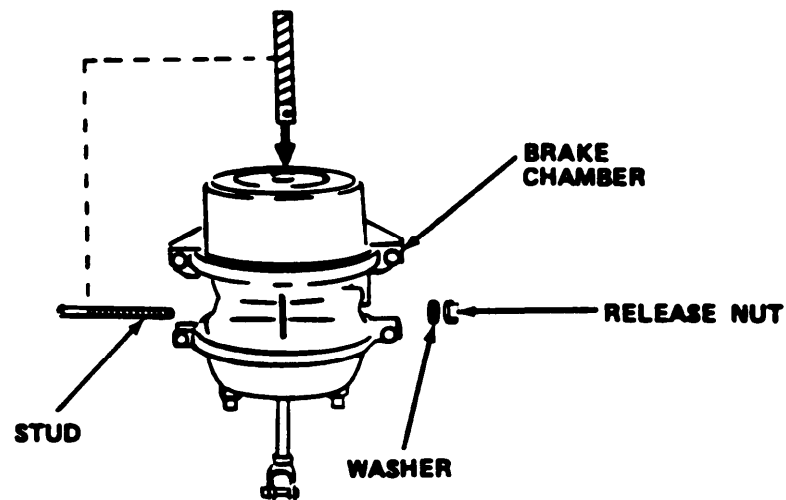

4. Remove release stud assembly from side pocket by removing the release nut and washer from the release stud and sliding out the release stud.

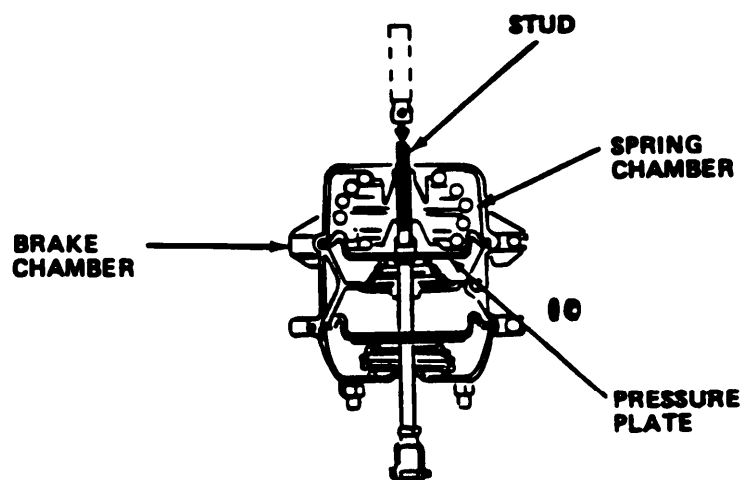

5. Insert release stud through opening (where cap was removed) in the spring chamber and insert into pressure plate.

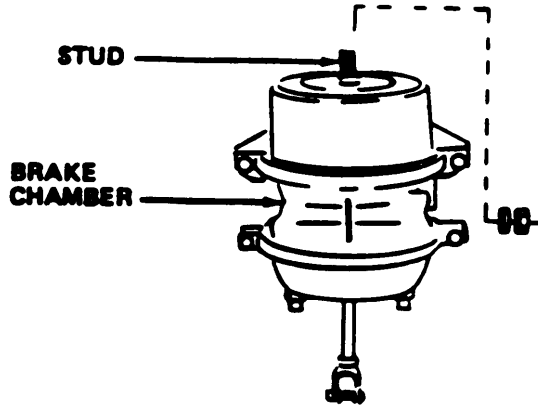

6. Turn release stud 1/4 turn to right in pressure plate to secure cross pin area of pressure plate and lock into manual release position.

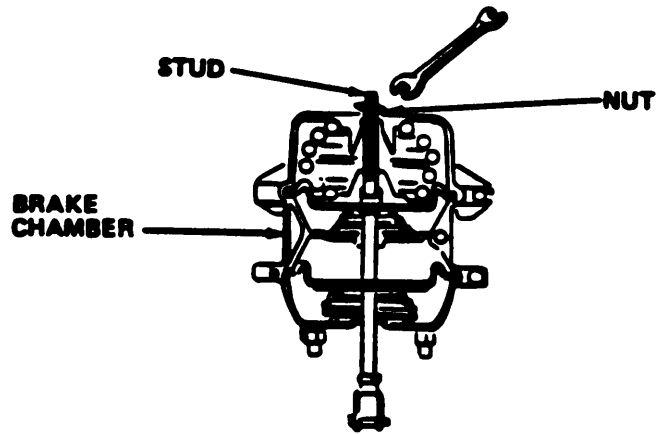

7. Assembly release stud washer and nut onto release stud.

**CAUTION**

DO NOT WREN RELEASE STUD.  
(MAXIMUM 50 LBS TORQUE.) EXCESSIVE  
TORQUE MAY DAMAGE PRESSURE PLATE.

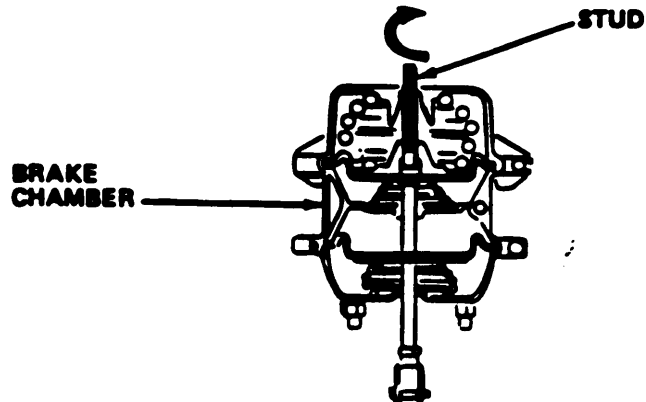

8. Turn release stud assembly nut with wrench until compression spring is fully caged. While doing so, check visually to make certain the pushrod (adapter pushrod or service pushrod) is retracting while tightening the release stud assembly nut.
9. Remove cotter pin and clevis pin from brake adjuster.
10. Remove two retaining nuts and washer, and remove brake chamber.
11. Install new brake chamber to brackets and secure with nuts and washers.
12. Reinstall clevis and clevis pin to brake adjuster and secure with cotter pin.
13. Loosen release stud nut, and remove stud.
14. Turn release stud to left to release cross pin and remove stud.
15. Reinstall release stud to side pocket, and secure with nut and washer.
16. Reinstall chamber cap.
17. Reinstall air hose and tighten connector assembly.
18. Adjust brakes. (4.4.1.21)
19. Pressurize system and check for leaks by coating fittings with soapy water solution and inspecting for presence of bubbles.

4.4.1.6 REPLACE OVERRIDE VALVE SELECTOR.

TOOLS: Flat-Tipped Screwdriver  
Combination Wrench Set  
Socket Head Wrench Set

SUPPLIES: Manual Override Valve  
Liquid Detergent  
Plastic Pail

1. Depressurize system by opening moisture ejectors.

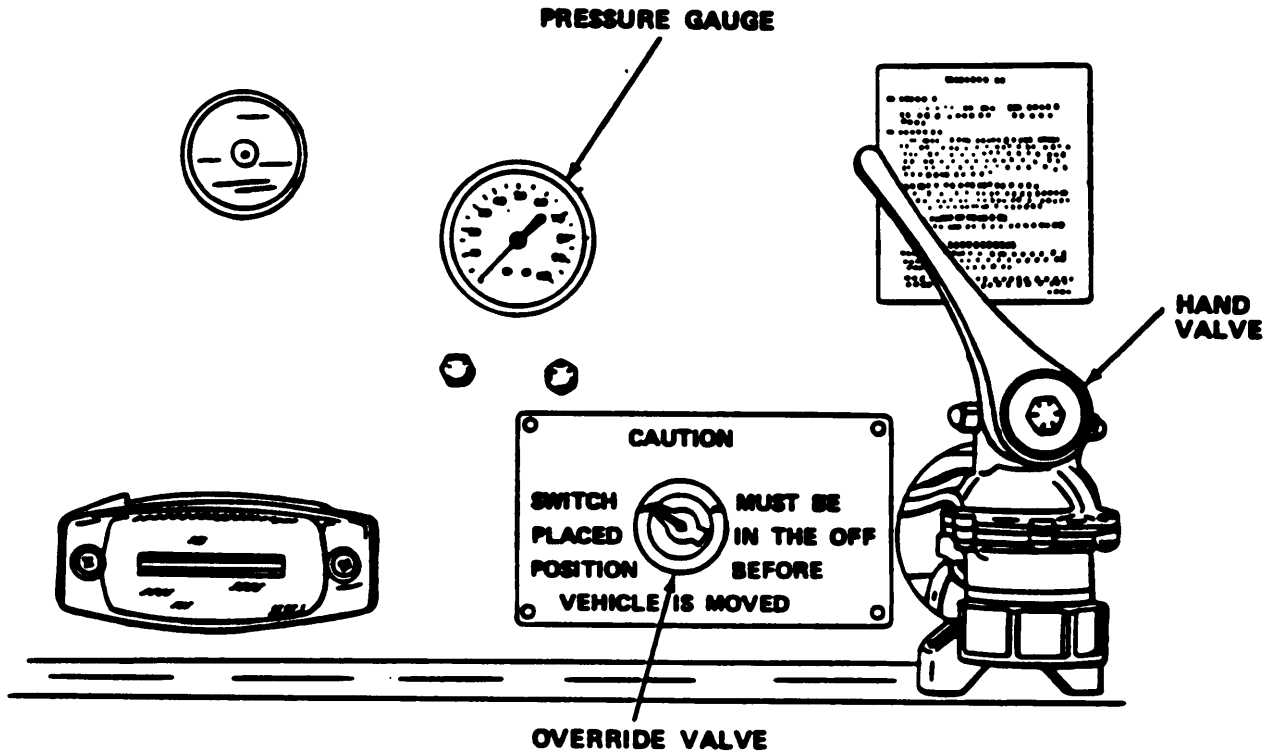

2. Loosen setscrew and remove.

**NOTE**

Male pipe end of air hose does not swivel. To remove the male end of an air hose from a component, disconnect the swivel at the other end of the air line. Then disconnect the air line from the chassis so that male pipe end turns freely.

3. Loosen connectors and remove both air hoses.

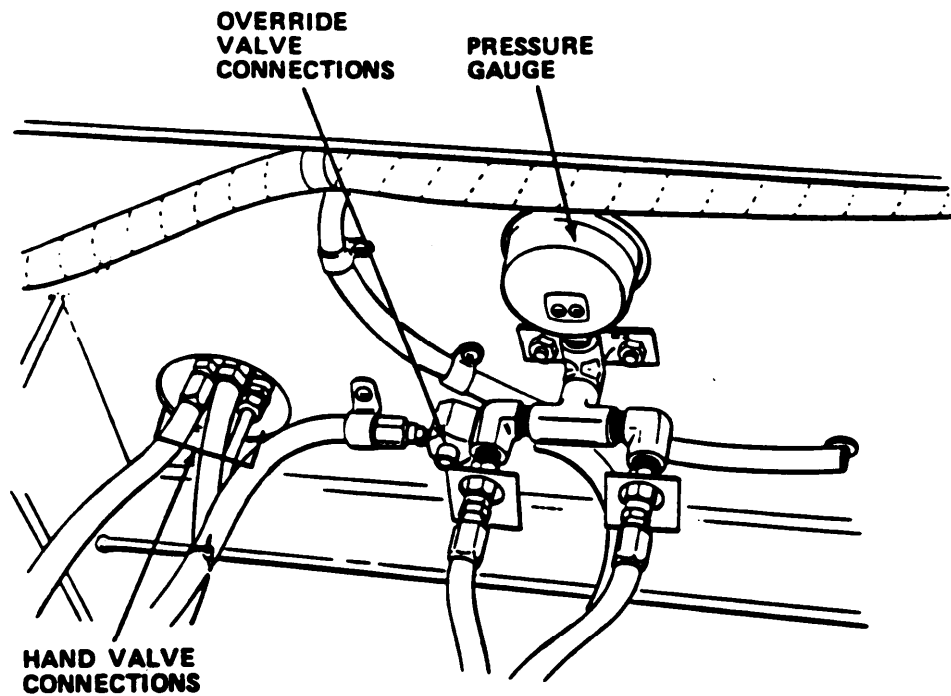

4. Remove retaining nut, washer and switch plate.
5. Remove valve from rear of frame.
6. Reinstall air hoses and tighten connectors.
7. Install new valve into frame.
8. Reinstall switch plate, washer and nut.
9. Reinstall knob and tighten socket head screw.
10. Repressurize system.
11. Check fittings for leaks by applying a soapy water solution and inspecting for air bubbles.

4.4.1.7 REPLACE PILOT VALVE.

TOOLS: Combination Wrench Set  
Cross-Tipped Screwdriver

SUPPLIES: Pilot Valve  
Liquid Detergent  
Plastic Pail

1. Repressurize system by opening moisture ejectors.

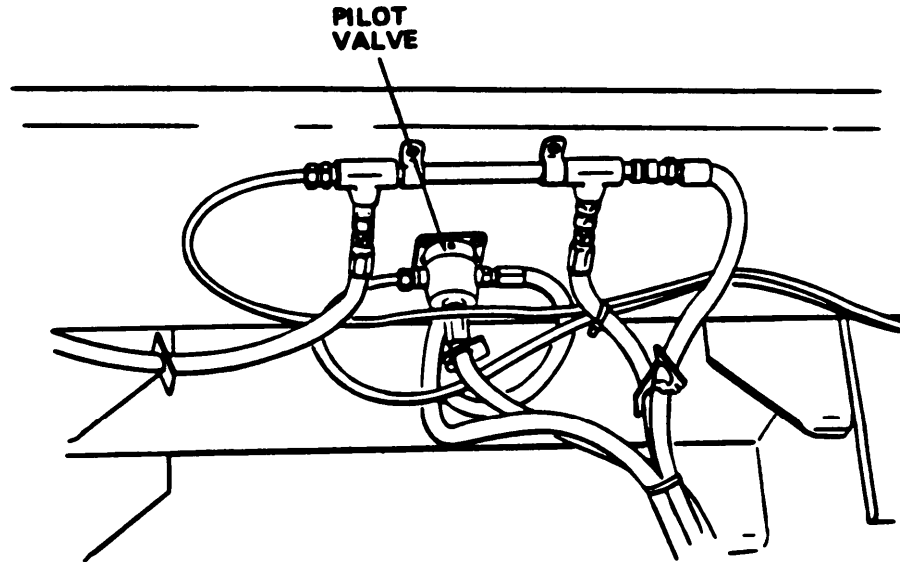

**NOTE**

Male pipe end of air hose does not swivel. To remove the male end of an air hose from a component, disconnect the swivel at the other end of the air line. Then disconnect the air line from the chassis so that the male pipe end turns freely.

2. Loosen fittings and remove five air hoses to pilot valve.
3. Remove four cross-tipped screws and remove pilot valve.
4. Install new pilot valve and retain with four screws.
5. Install air hoses in proper reassembly order and tighten fittings securely.
6. Repressurize air system.
7. Check fittings for leaks by applying a soapy water solution and inspecting for air bubbles.

4.4.1.8 REPLACE HAND LEVER VALVE.

TOOLS: Combination Wrench Set

SUPPLIES: Hand Lever Valve  
Liquid Detergent  
Plastic Pail

1. Repressurize system by opening moisture ejectors.

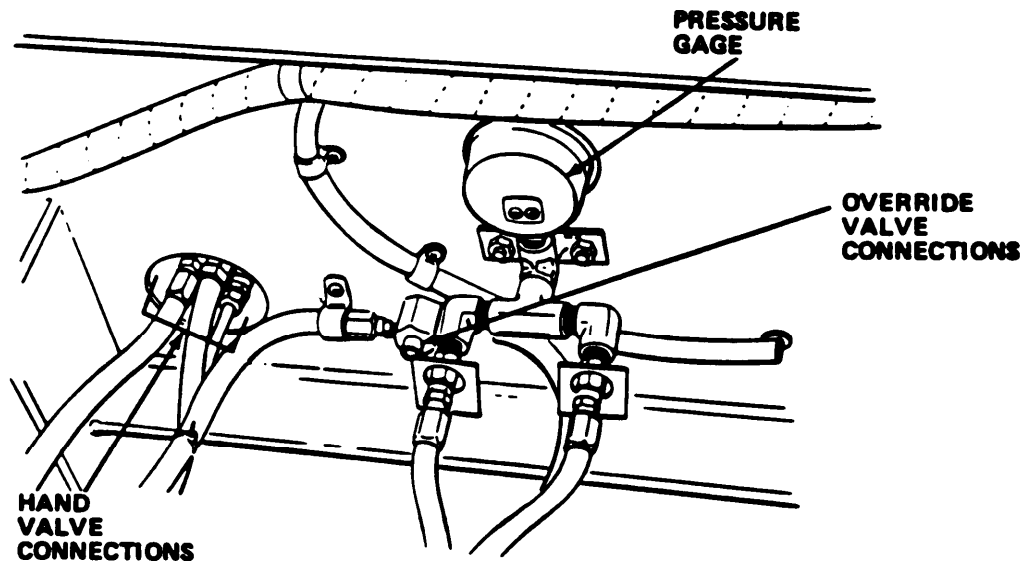

2. Loosen fittings and remove two air hoses and exhaust hose.

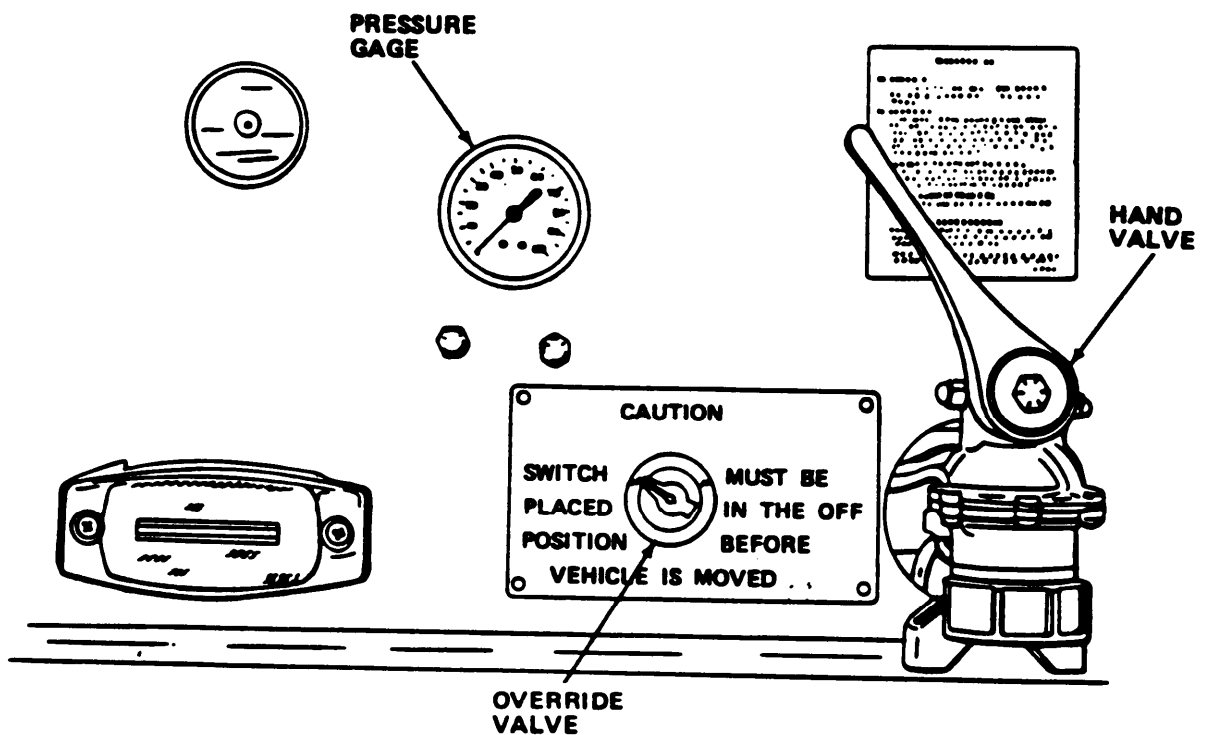

3. Remove two bolts, nuts and washers retaining hand valve to frame. Remove hand valve.

4. Install new hand valve and retain with bolts, nuts and washers.
5. Reinstall air hoses and exhaust hose in proper reassembly order to valve and tighten fittings securely.
6. Check for air leaks by applying a soapy water solution to fittings and inspecting for bubbles.

#### 4. 4. 1. 9 REPLACE GAGE

TOOLS: Combination Wrench Set

SUPPLIES: Air Gage  
Thread Sealer (TFL)  
Solvent  
Cotton Cloth

1. Depressurize system by opening moisture ejectors.

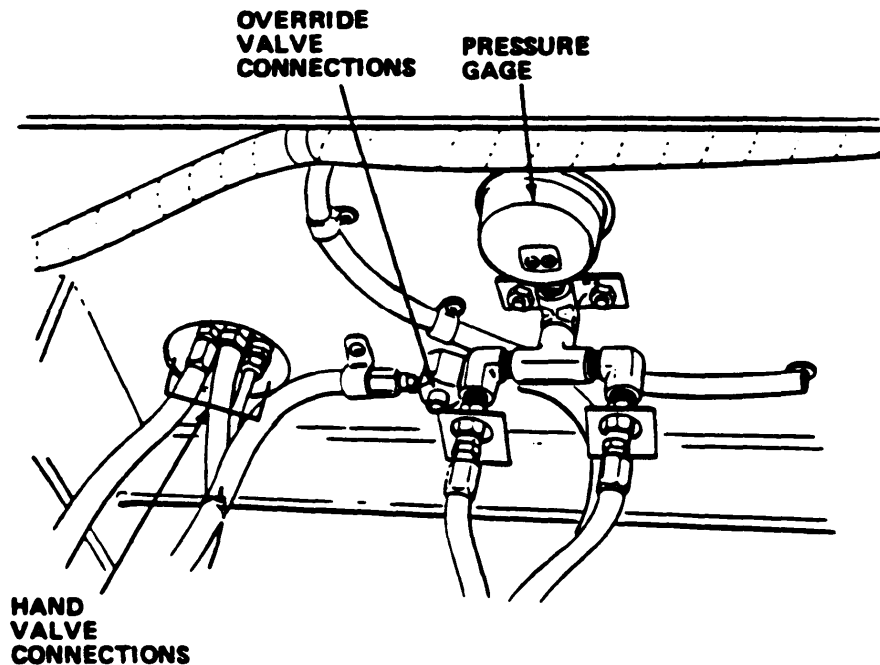

2. Loosen fittings and remove two air hoses and exhaust hose.
3. Remove two bolts, nuts and washers retaining gage to frame. Remove gage.
4. Remove two elbow fittings from gage and clean with solvent-saturated, cotton cloth.



**CAUTION**

DO NOT ALLOW EXCESS SEALANT TO ENTER AIR SYSTEM. SEALANT MAY OBSTRUCT LINES IF INTRODUCED INTO AIR SYSTEM.

5. Apply thread sealant to elbows and reinstall into new gage.
6. Install new gage and retain with bolts, nuts and washers.
7. Reinstall air hoses and tighten securely.
8. Check for air leaks by applying a soapy water solution to fittings and inspecting for bubbles.

4. 4. 1. 10 REPLACE LANDING GEAR ASSEMBLY.

TOOLS: Tool Kit

SUPPLIES: Landing Gear Assembly

1. Extend front chassis leveling jacks to their maximum height.
2. With front leveling jacks supporting chassis, retract landing gear. This will ensure enough clearance to allow removal of the landing gear.

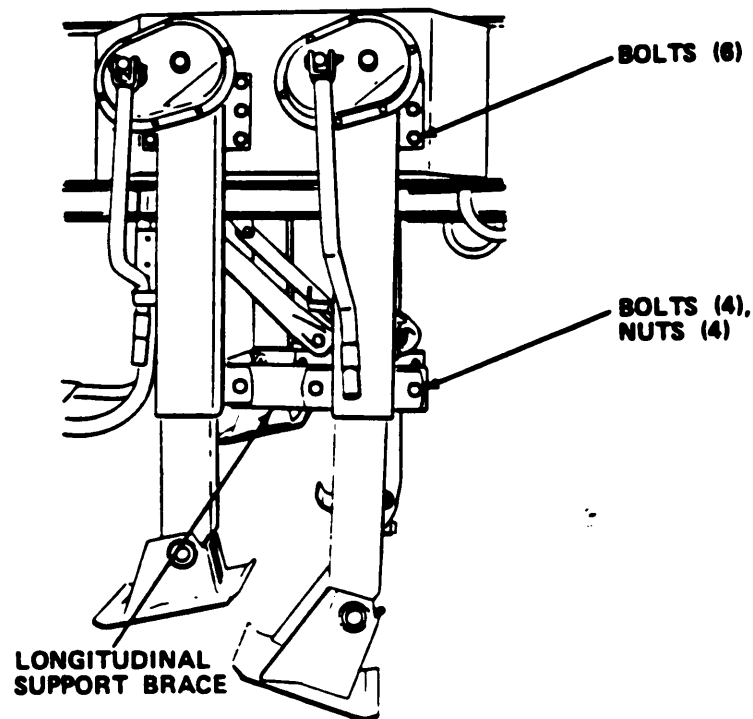
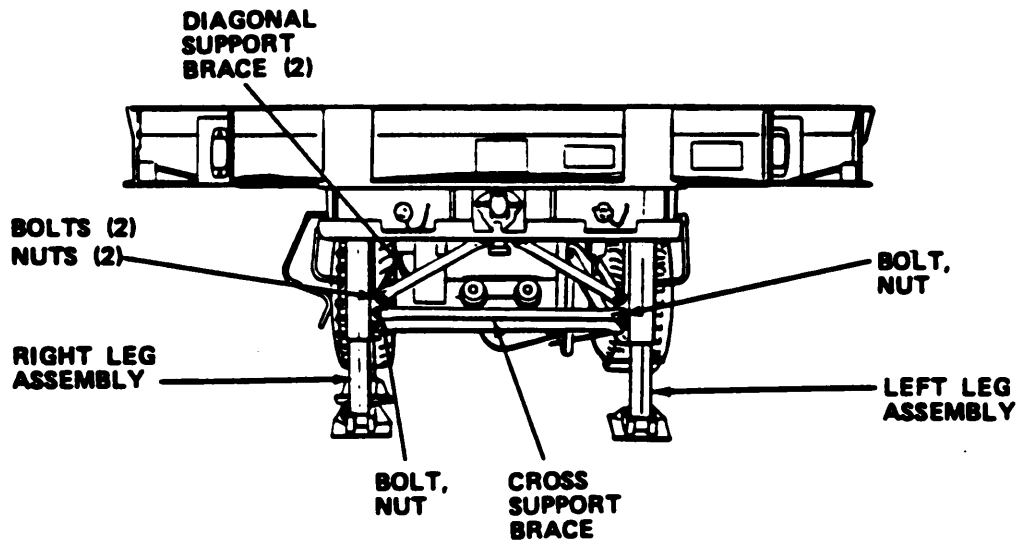

3. Remove two nuts, two bolts and cross support brace.
4. Remove two nuts and two bolts which secure diagonal support braces to landing gear.
5. Remove four nuts and four bolts which secure longitudinal support braces to leg assemblies.

**WARNING**

SUPPORT THE LANDING GEAR PROPERLY TO PREVENT IT FROM FALLING.

6. Extend landing gear just enough to support its own weight so it will not fall when mounting bolts are removed.
7. Remove two bolts which connect the cross shaft to the two leg assemblies.
8. Remove the six bolts which secure the right leg assembly to the chassis and remove the leg assembly.
9. Remove the six bolts which secure the left leg assembly to the chassis and remove the leg assembly.
10. Place new left leg assembly in position and secure to chassis with six bolts.
11. Place new right leg assembly in position and secure to chassis with six bolts.
12. Reinstall cross-shaft and secure to the two leg assemblies with two bolts.
13. Reinstall four bolts and nuts which secure longitudinal support braces to leg assemblies.
14. Reinstall two bolts and nuts which secure diagonal support braces to landing gear.
15. Reinstall cross support brace and secure to landing gear with two bolts and nuts.

4. 4. 1. 11 REPLACE BACKSLAP CHAMBER.

TOOLS: Tool Kit

SUPPLIES: Air Brake chamber  
Plastic Pail  
Liquid Detergent

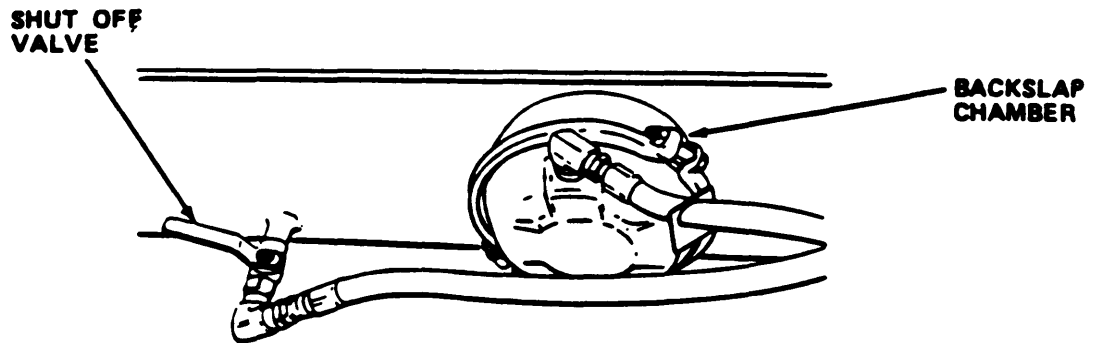

**NOTE**

Male pipe end of air hose does not swivel. To remove the male end of an air hose from a component, disconnect the swivel at the other end of the air line. Then disconnect the air line from the chassis so that the male pipe end turns freely.

1. Remove air hose from chamber.
2. Remove two nuts and washers retaining chamber.
3. Remove clip and pin retaining clevis to backslap lever.
4. Remove backslap chamber.
5. Install new backslap chamber.
6. Reinstall clevis to backslap lever.
7. Reinstall clevis retaining pin and clip.
8. Reinstall washers and nuts retaining chamber.

CAUTION

AIR HOSE MAY BE DAMAGED IF TWISTED.

9. Reinstall air hose and tighten securely.
10. Check hose for leaks by coating with soapy water solution while cycling brakes and watching for bubbles.

## 4. 4. 1. 12 REPLACE AUXILIARY SERVICE RELAY.

TOOLS: Tool Kit

SUPPLIES: Auxiliary Service Relay Valve.  
Thread Sealant (TFL)  
Liquid Detergent  
Plastic Pail  
Cotton Cloth  
Solvent

1. Repressurize air system by opening moisture ejector valves.

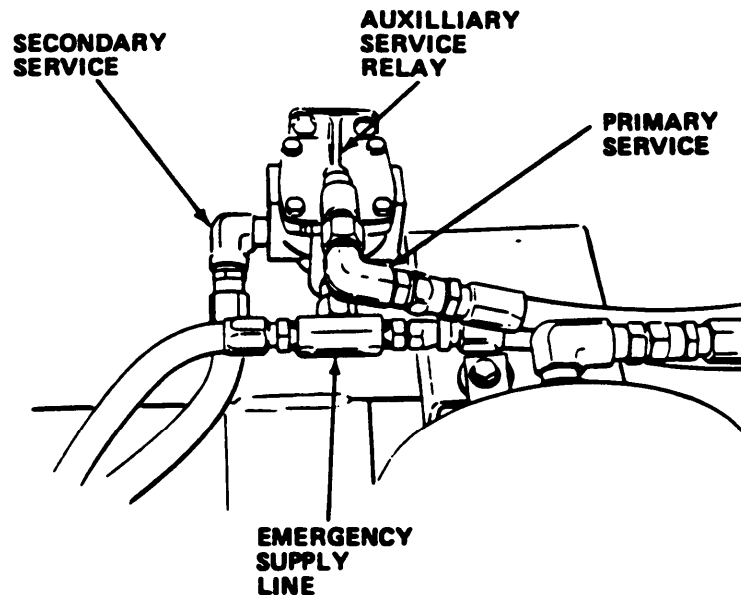
**NOTE**

Male pipe end of air hose does not swivel. To remove the male end of an air hose from a component, disconnect the swivel at the other end of the air line. Then disconnect the air line from the chassis so that **the male pipe end turns freely.**

2. Remove four air hoses from relay valve. Note positions to ensure proper reassembly.
3. Remove two nuts, washers and bolts retaining relay valve to chassis frame. Remove relay valve.
4. Remove T-hose fitting and adapter from valve.
5. Remove two elbow fittings and adapter from valve.

6. Clean fittings and adapter threads with cloth and solvent.

**CAUTION**

DO NOT ALLOW EXCESS THREAD SEALANT TO ENTER VALVE.

7. Apply thread sealant to threads of elbow fitting and reinstall into new valve. Tighten securely.
8. Apply thread sealant to T-fitting adapter and reinstall fitting and adapter into valve and tighten securely.
9. Install new relay valve to frame and retain with bolts, nuts and washers.
10. Reinstall air hoses to fittings in proper reassembly order.
11. Check air lines for leaks by pressurizing system, then applying soapy water solution to fittings and inspecting for presence of air bubbles.

4. 4. 1. 13 REPLACE HITCH SHUTOFF VALVE.

TOOLS: Tool Kit

SUPPLIES: Hitch Shutoff Valve  
Thread Sealant (TFL)  
Solvent  
Cotton Cloth  
Liquid Detergent  
Plastic Pail

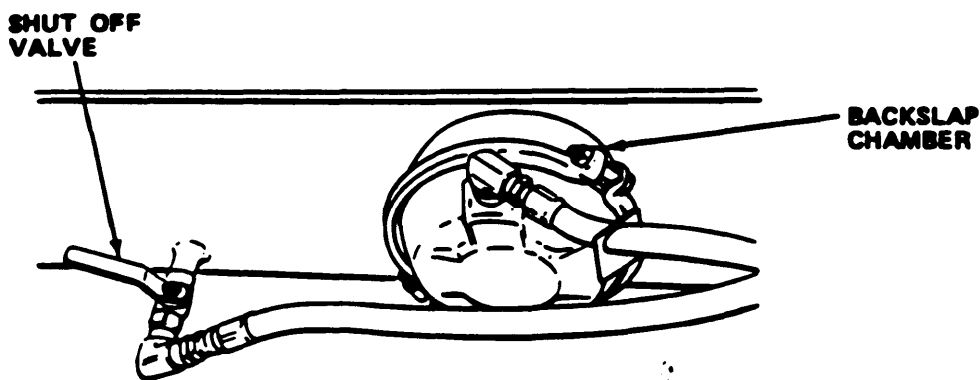

1. Open shutoff valve and depressurize system.
2. Remove air hose from valve.
3. Remove elbow from valve.

4. Remove valve from air line.
5. Clean all threaded parts with solvent-saturated, cotton cloth.

**CAUTION**

DO NOT ALLOW EXCESS SEALANT TO ENTER AIR LINES. SEALANT MAY OBSTRUCT AIR LINE IF INTRODUCED INTO AIR SYSTEM.

6. Apply sealant to air line threads and install new valve.
7. Apply sealant to threads of elbow and reinstall into valve.
8. Reinstall hose and tighten securely.
9. Check for leaks by pressurizing system, applying soapy water solution to fittings and inspecting for presence of air bubbles.

**4.4.1.14 REPLACE AIR SPRING.**

TOOLS: Tool Kit  
Torque Wrench (0-150 ft lbs)

SUPPLIES: Air Spring

**CAUTION**

BE SURE CHASSIS IS PARKED ON LEVEL GROUND AND IS UNHOOKED FROM TRUCK BEFORE PROCEEDING TO PREVENT PERSONNEL INJURY.

1. Extend chassis leveling jacks to raise chassis high enough to relieve tension on air spring.

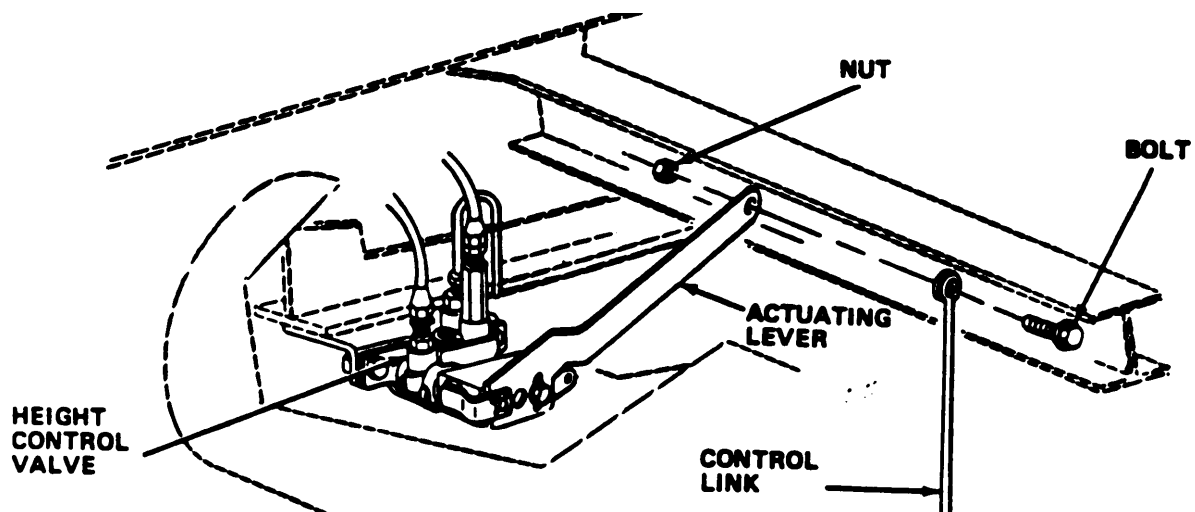

2. Remove nut and bolt which secure control link to height control valve actuating lever.

- Depress actuating lever to release air pressure on air spring. (Allow approximately five sec for air to start flowing through valve, due to built-in time delay.) Hold lever in position until pressure in air spring has equalized with atmospheric pressure.

**WARNING**

ACTUATING LEVER MUST REMAIN IN DEFLATE OR NEUTRAL POSITION TO ENSURE SYSTEM AIR PRESSURE IS NOT APPLIED TO AIR SPRING DURING MAINTENANCE & PRESSURIZATION OF AIR SPRING MAY RESULT IN PERSONNEL INJURY.

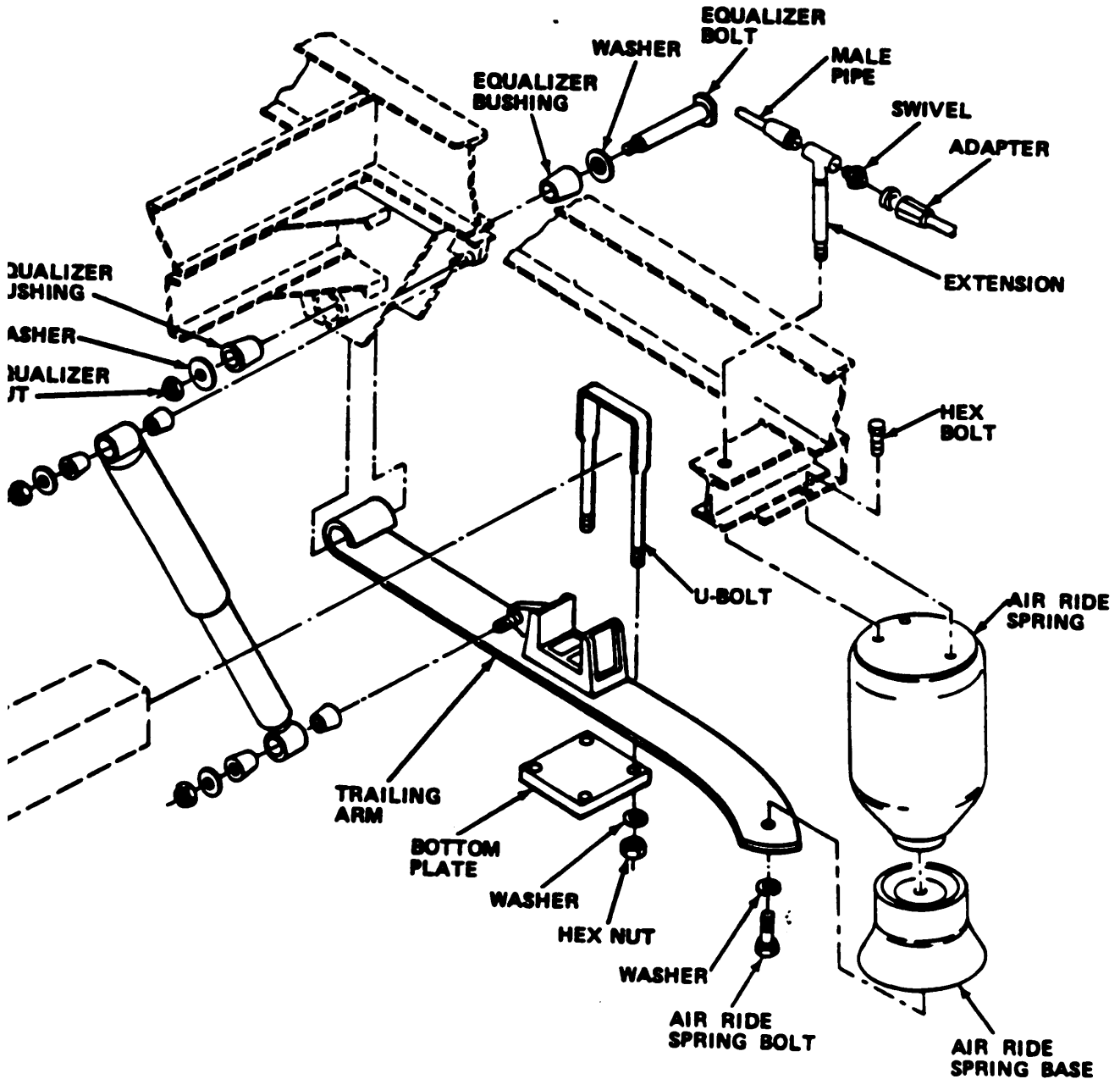



4. Remove bolt which secures trailing arm to bottom of air spring.

**NOTE**

Male pipe end of air hose does not swivel. To remove the male end of an air hose from a component, disconnect the swivel at the other end of the air line. Then disconnect the air line from the chassis so that the male pipe end turns freely.

5. Disconnect air line at top of air spring.
6. Remove two nuts which secure top of air spring to rear mounting assembly.
7. Remove air spring.
8. Install new air spring and secure to rear mounting assembly with two nuts and torque to 60-70 ft lbs.
9. Secure bottom of air spring to trailing arm with bolt and torque to 60-70 ft lbs.

**NOTE**

Be sure air spring does not twist while tightening bolt.

10. Reconnect air line at top of air spring using thread sealant.
11. Reconnect control link to height control valve and secure with nut and bolt.
12. Retract chassis leveling jacks.

**NOTE**

When leveling jacks have been retracted, be sure height control valve has allowed air spring to be inflated.

4.4.1.15 REPLACE SHOCK ABSORBER.

TOOLS: Tool Kit  
Torque Wrench (0-500 ft lb)

SUPPLIES: Shock Mounting Bushing  
Shock Absorber

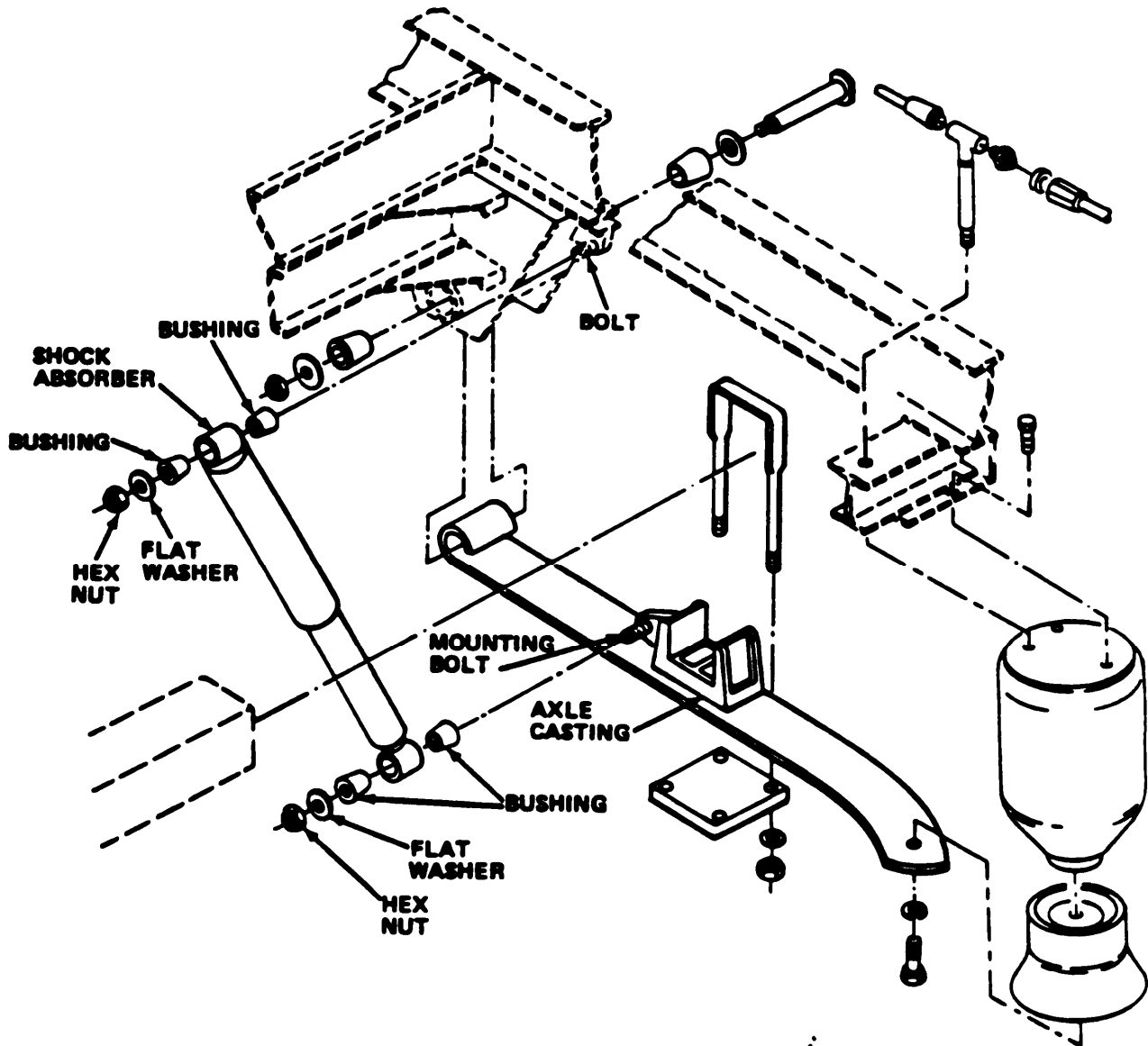

1. Remove two nuts and flat washers which secure shock absorber to upper and lower mounts.
2. Remove shock absorber and bushings.
3. Install new shock absorber and new boushings.
4. Install two nuts which secure shock absorber to upper and lower mounts and torque to 190-210 ft lbs.

4.4.1.16 REPLACE EQUALIZER BUSHING.

TOOLS: Combination Wrench (1 1/2 in.)  
Torque Wrench  
Hammer (4 lb)  
Long Punch (3/8 pt)  
Socket (1 1/2 in.)

SUPPLIES: Equalizer Bushing

CAUTION

BE SURE CHASSIS IS PARKED ON LEVEL GROUND  
AND IS UNHOOKED FROM TRUCK BEFORE PROCEED-  
ING TO PREVENT PERSONNEL INJURY.

1. Extend chassis leveling jacks to raise chassis high enough to relieve tension on qualizer bushing.
2. Disconnect shock absorber from axle.
3. Remove nut and washer which secures equalizer bolt.
4. Using a hammer and long punch, remove the equalizer bolt and washer.
5. Remove two equalizer bushings.
6. Install two new qualizer bushings.
7. Install the equalizer bolt and washer, and secure with nut and washer. Torque nut to 340 to 360 ft. lb. (46.9 to 49.7 N•m)
8. Retract chassis leveling jacks.

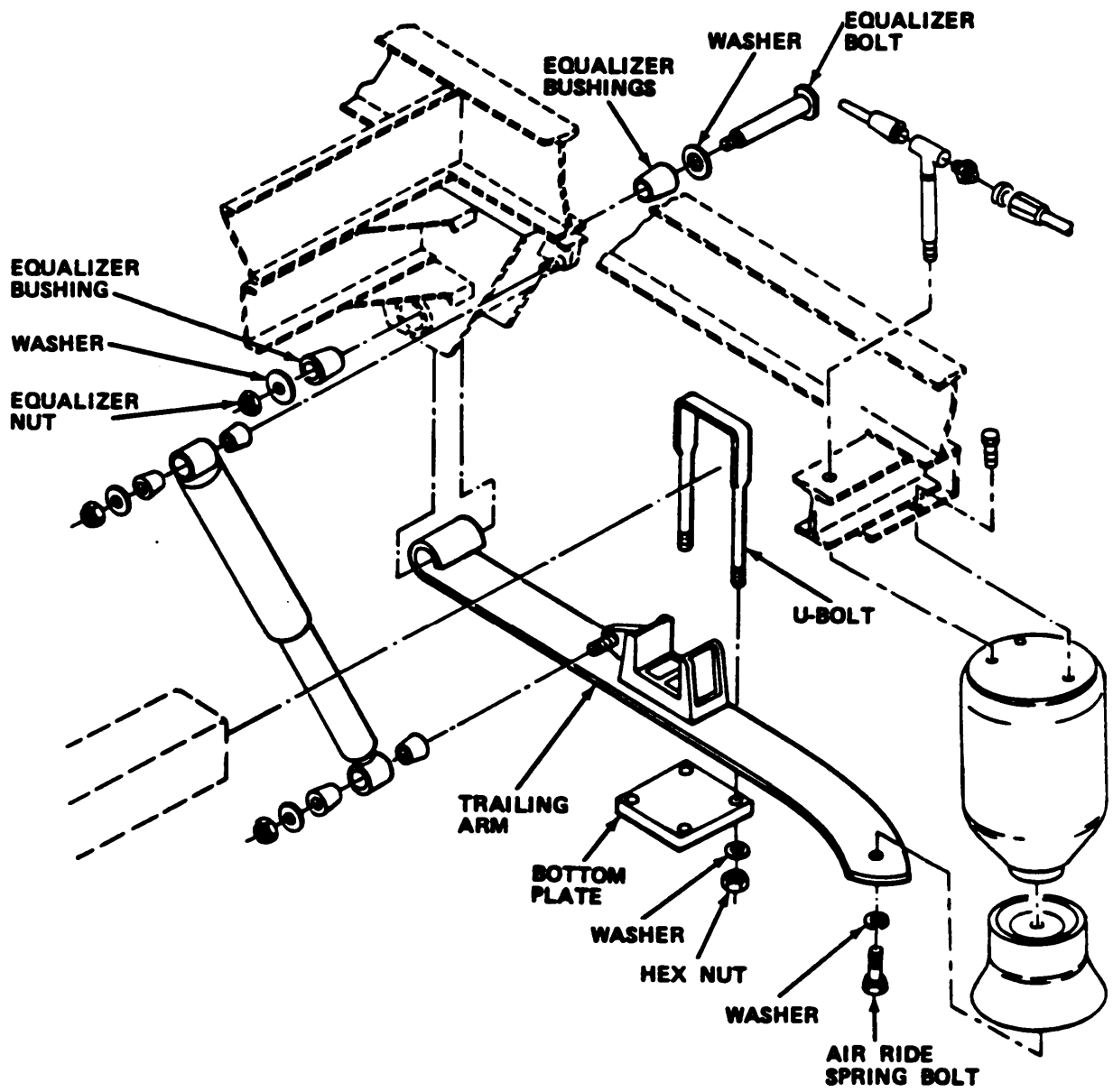

4.4.1.17 REPLACE U-BUTS.

TOOLS: Combination Wrench (1 1/2 in.)  
ToRque Wrench (0-1000 ft lb)  
Socket (1 1/2 in.)

SUPPLIES: U-Bolts

**CAUTION**

BE SURE CHASSIS IS PARKED ON LEVEL GROUND  
AND IS UNHOOKED FROM TRUCK BEFORE PROCEED-  
ING TO PREVENT PERSONNEL INJURY.

1. Extend chassis leveling jacks to raise chassis high enough to relieve tension on U-bolts.

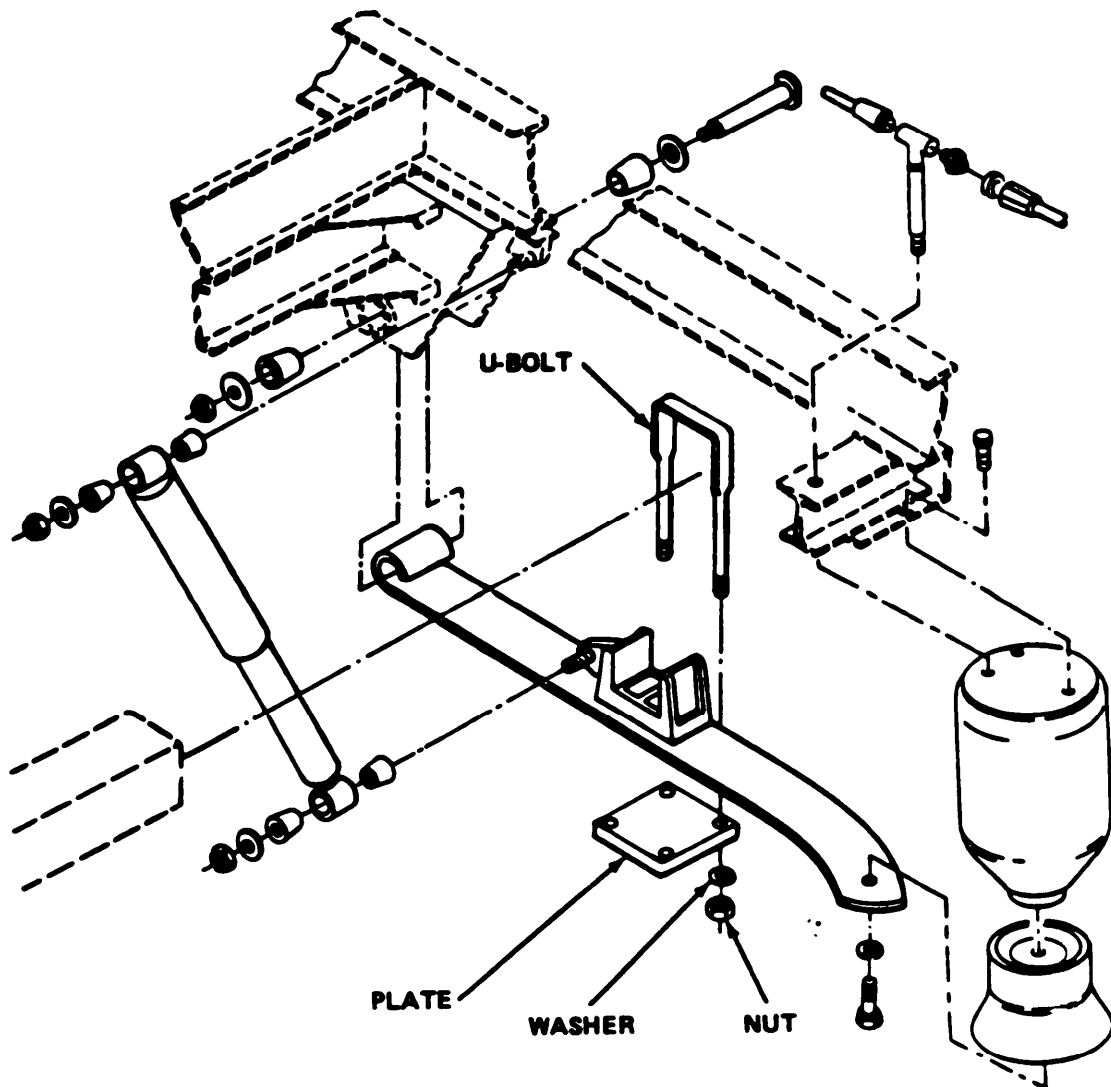

2. Remove four nuts and washers.
3. Remove bottom plate.
4. Remove two U-bolts (4).
5. Install two new U-bolts.
6. Install bottom plate and secure to U-bolt with four nuts and washers. Alternately torque nuts until 700-750 ft lbs is achieved.
7. Retract chassis leveling jacks.

**4.4.1.18 REPLACE MOISTURE EJECTOR.**

TOOLS: Adjustable Wrench

SUPPLIES: Thread Sealant (TFL)  
Automatic Moisture Ejector

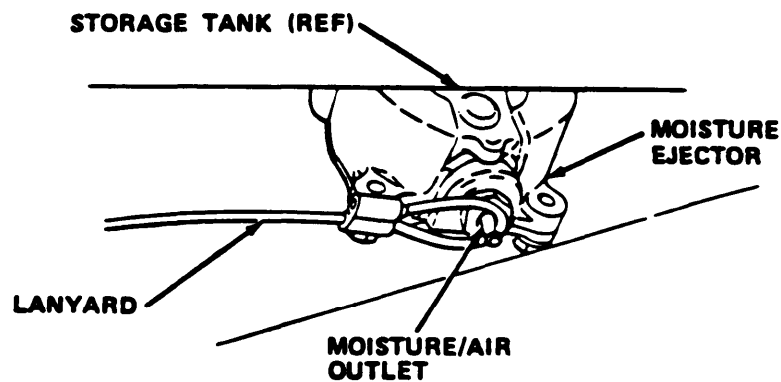

1. Pull on ejector lanyard until system is depressurized.
2. Remove ring connecting ejector lever to lanyard.
3. Unscrew ejector housing from bottom of tank.

**CAUTION**

DO NOT ALLOW THREAD SEALANT  
TO CONTAMINATE AIR SYSTEM.

4. Spread some thread sealant on threads of new ejector housing. Clean old thread sealant from tank threads.
5. Screw new ejector into bottom of tank. Tighten securely.
6. Attach ring and lanyard cable to ejector.

4.4.1.19 REPLACE REFLECTOR.

TOOLS: Flat-Tipped Screwdriver (1/4 in.)

SUPPLIES: Red Reflector  
Amber Reflector

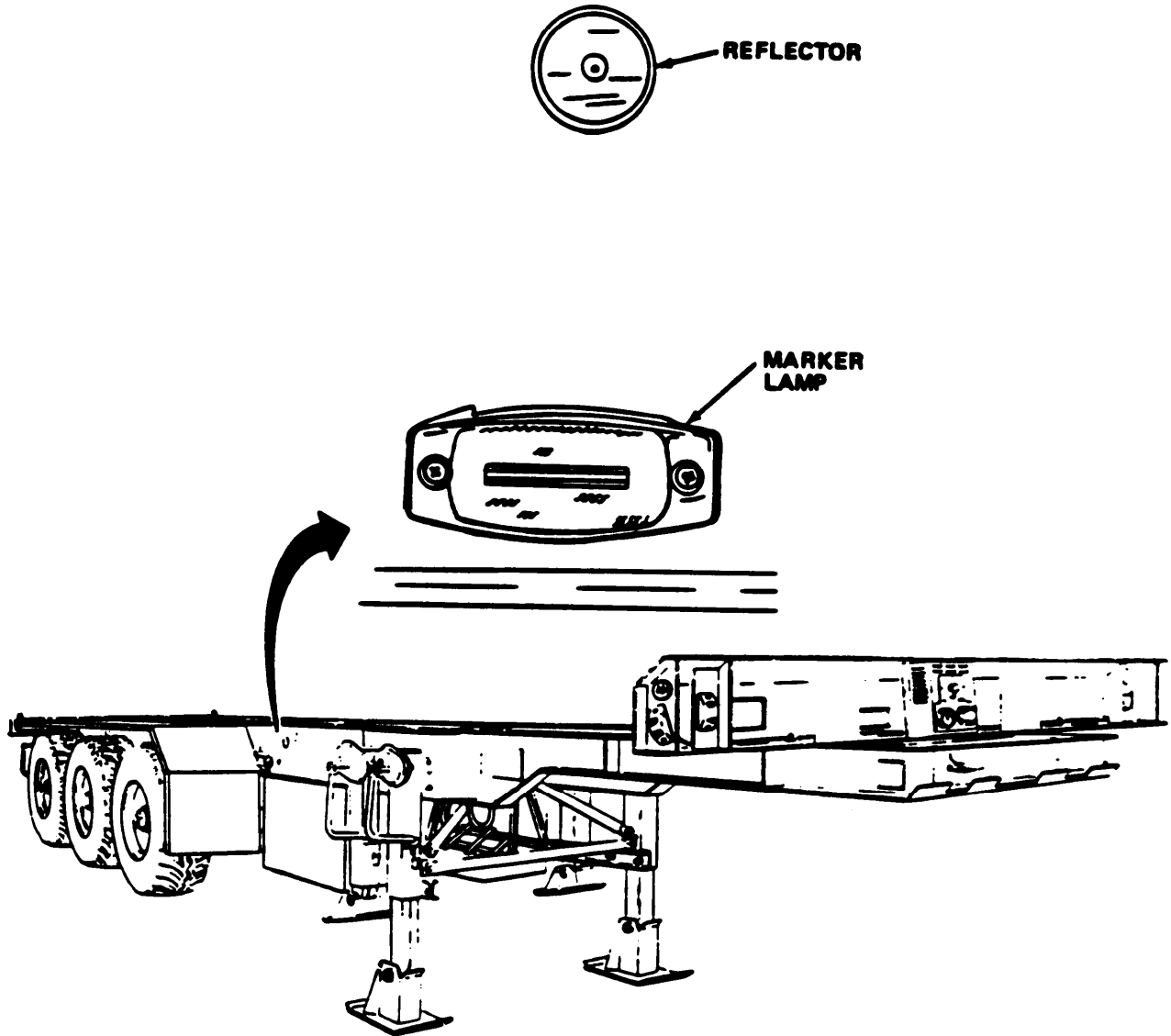

1. Remove screw holding reflector.
2. Pull off reflector and gasket.
3. Insert new gasket and reflector.
4. Replace screw and tighten.



4.4.1.20 REPLACE VOLTAGE CONTROL UNIT.

TOOLS: Flat-Tipped Screw driver (1/4 in.)  
Adjustable Wrench (6 in.)

SUPPLIES: Voltage Control Unit

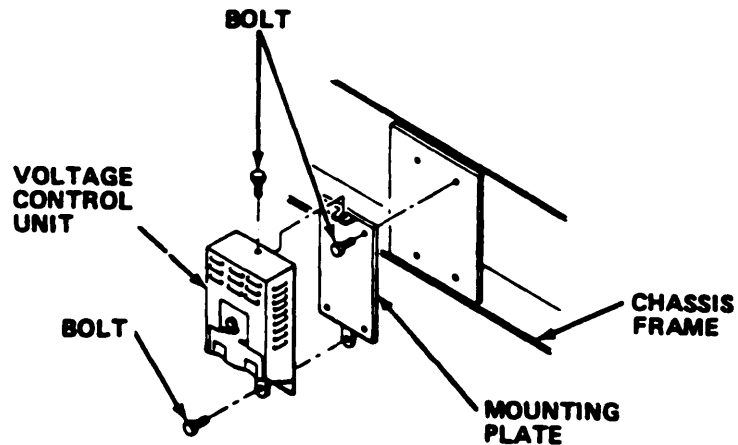

1. Remove two bolts which secure the voltage control unit to its mounting plate and remove the unit.
2. Remove the four bolts which secure the mounting plate to the chassis and remove the mounting plate.
3. Install the new mounting plate on the chassis and secure with four bolts.
4. Install the new voltage control unit on the mounting plate and secure with two bolts.

4.4.1.21 INITIAL BRAKE ADJUSTMENT.

TOOLS: Adjustable Wrench (8 in.)

SUPPLIES: Jack

1. Position chassis on level ground (preferably concrete) with tractor.
2. Lower chassis jacks so that chassis is in a level position.
3. Uncouple tractor from chassis, but leave brake hoses connected to apply air pressure to chassis brake system to relieve the spring brake pressure.

**CAUTION**

WHEN JACKING AGAINST THE AXLE, BE CAREFUL TO USE A JACK WITH A HEAD LARGE ENOUGH TO DISTRIBUTE THE LOAD OR USE WOODEN BLOCKS AS A CUSHION BETWEEN THE AXLE AND THE JACK.

4. Chock one wheel opposite the side to be raised to prevent trailer movement. Place jack on a solid foundation to prevent it from slipping out of position and raise wheel to be adjusted clear of ground.

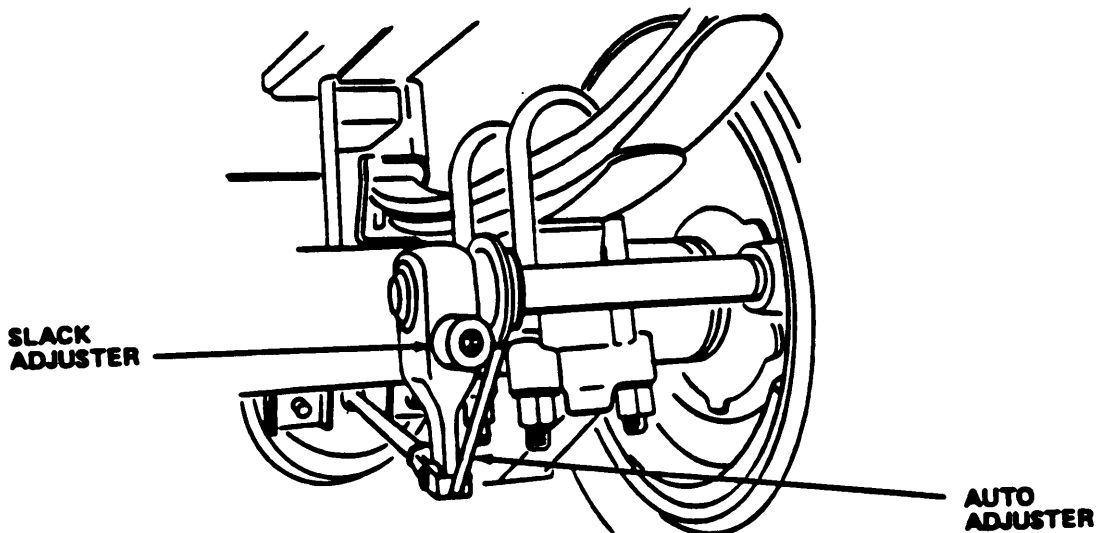

5. Position a wrench on the slack adjuster adjusting nut, and turn to the right until the brakes lock. Turn wrench to the left three notches or until wheel turns freely without brake shoe drag.

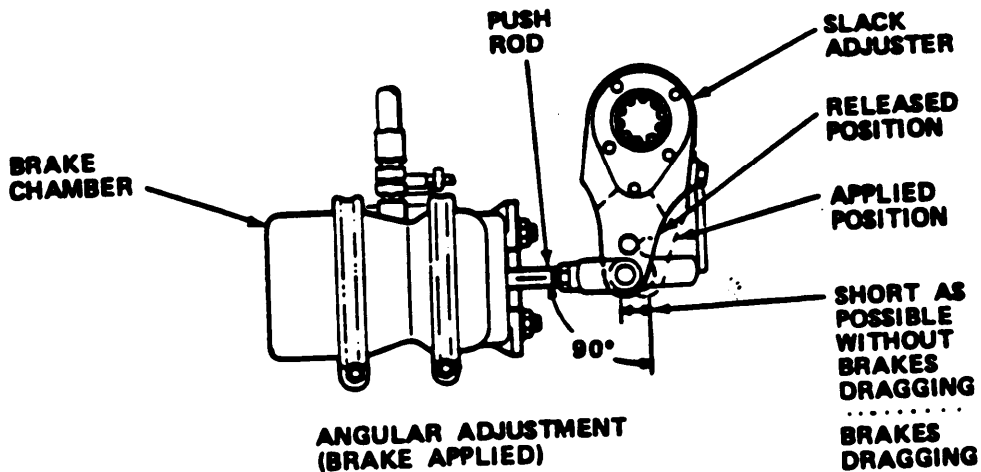

6. Apply brakes and hold application. The angle on the slack adjusters should not be less than 90 degrees.

**WARNING**

WHEN ADJUSTING BRAKES WITH SPRING BRAKE CHAMBERS, DO NOT REMOVE PUSHROD CLEVIS PIN OR LOOSEN MOUNTING NUTS UNLESS CHAMBER IS DISABLED BY CAGING.

**NOTE**

All slack adjusters should be set at the same approximate angle.

7. Adjust angle by shortening or lengthening pushrod at clevis yoke as required.
8. Repeat procedure for remaining five brakes.
9. Lower jack. Disconnect gladhands to set chassis brakes and remove wheel chocks.

4.4.1.22 REPLACE LEVELING JACK.

TOOLS: Tool Kit

SUPPLIES: Leveling Jack

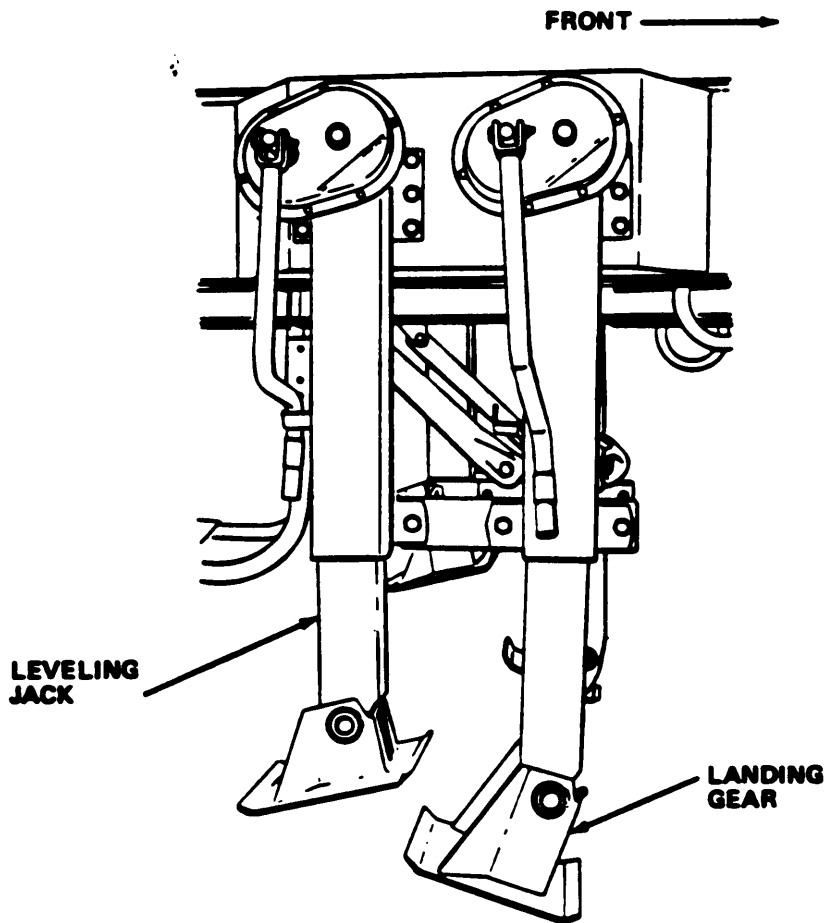

**WARNING**

SUPPORT LEVELING JACKS BEFORE ATTEMPTING TO REMOVE THEM. FAILURE TO DO SO COULD RESULT IN PERSONNEL INJURY.

1. Remove two bolts and nuts which secure leveling jack to braces.
2. Remove six bolts which secure leveling jack to chassis and remove jack.
3. Install new jack in position and secure to chassis with six bolts.
4. Install two bolts and nuts which secure jack to braces.

4.4.1.23 ADJUST HEIGHT CONTROL.

TOOLS: Flat-Tipped Screwdriver

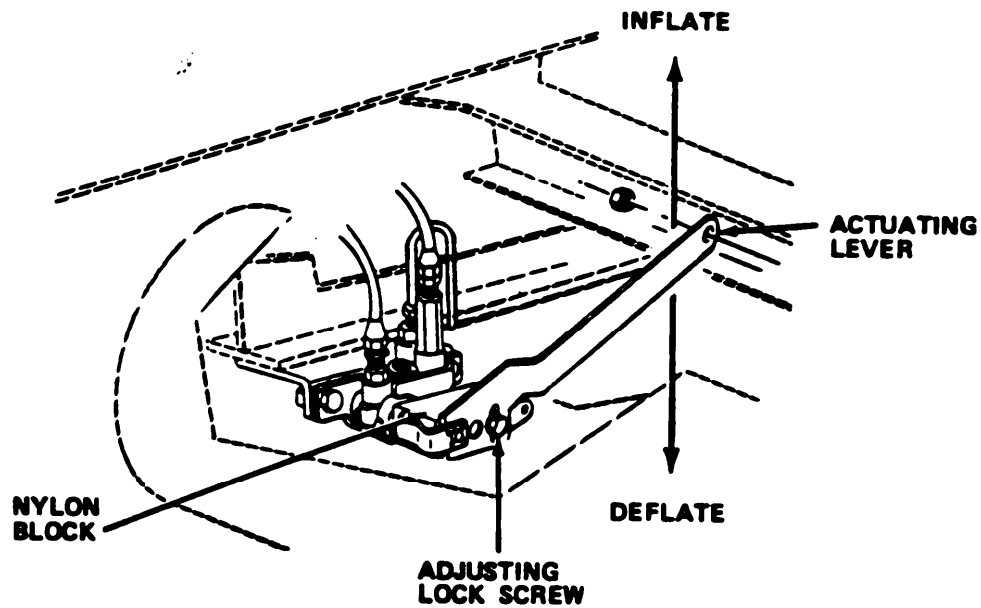

1. Loosen adjusting lock screw.

NOTE

Allow approximately five sec for air to start flowing due to built-in time delay.

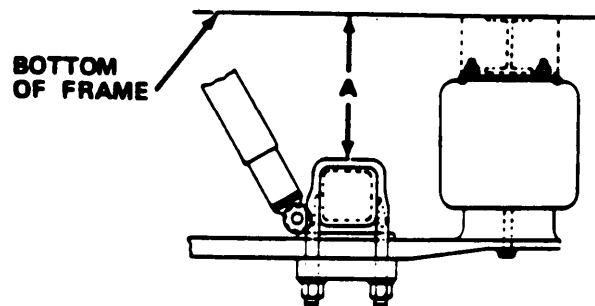

2. Move actuating lever nylon block to deflate or to inflate air springs until axle-to-frame height is 12.25 to 12.75 in. (311 to 324 mm).
3. Tighten adjusting lock screw.

4.4.1.24 REPLACE HEIGHT CONTROL VALVE.

TOOLS: Tool Kit

SUPPLIES: Height Control Valve  
Liquid Detergent  
Plastic Pail

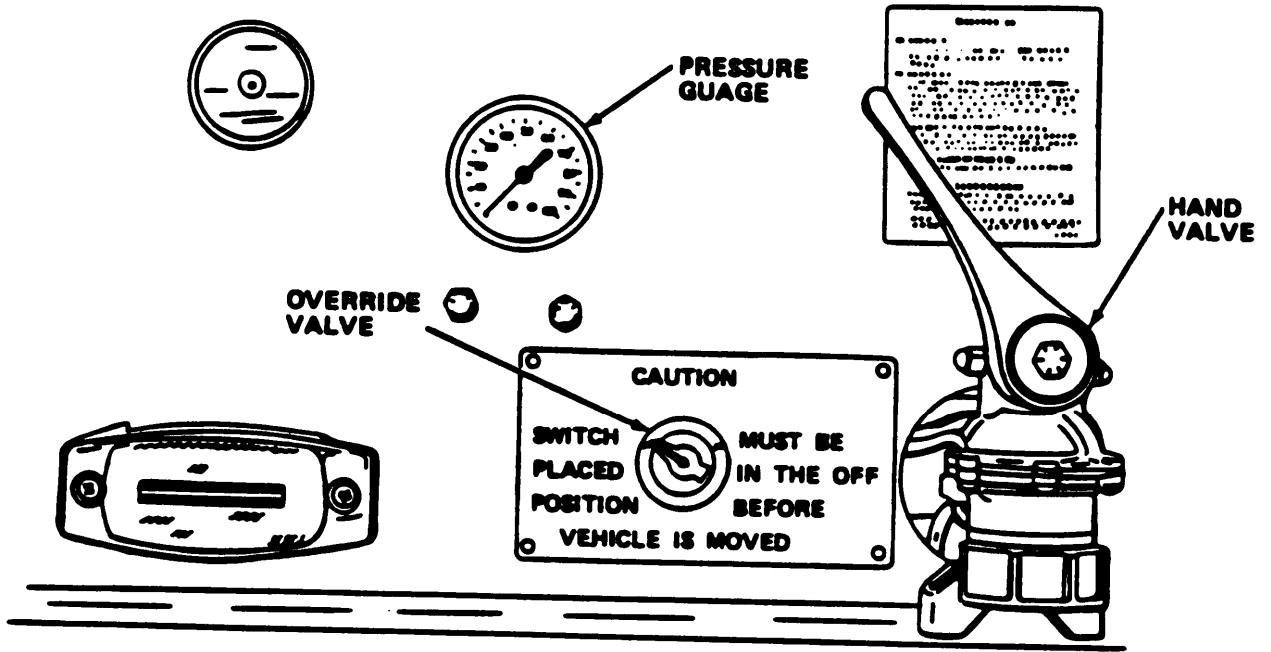

1. Turn manual override valve selector switch to ON.

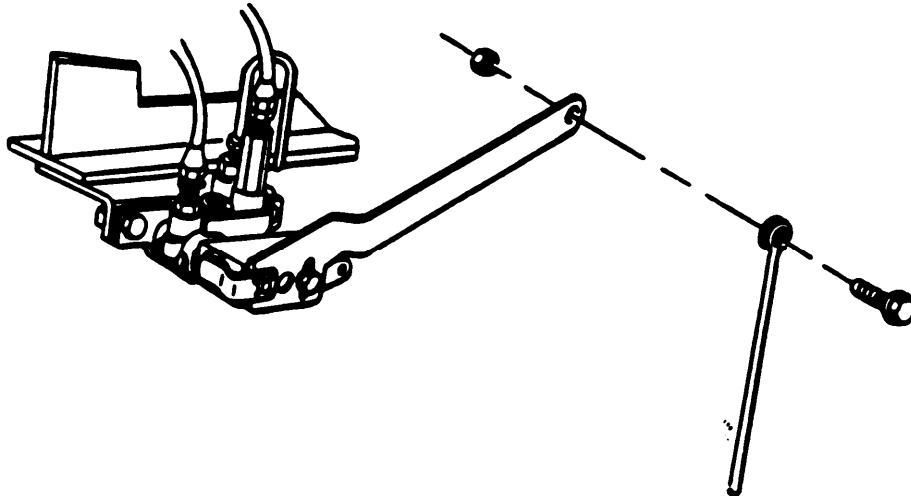

2. Tag and loosen connectors and remove two air hoses from valve.
3. Remove bolt and nut which retains linkage to valve arm.
4. Remove two bolts, nuts and washers retaining valve to bracket and remove valve.
5. Install new valve to bracket and retain with bolts, nuts and washers.
6. Reinstall linkage and retain with bolt, nut and washers.
7. Reinstall air hoses with thread sealant and tighten connectors securely.
8. Turn manual override valve selector switch to OFF.

**NOTE**

Allow approximately see for air to start flowing through valve due to built-in-time delay.

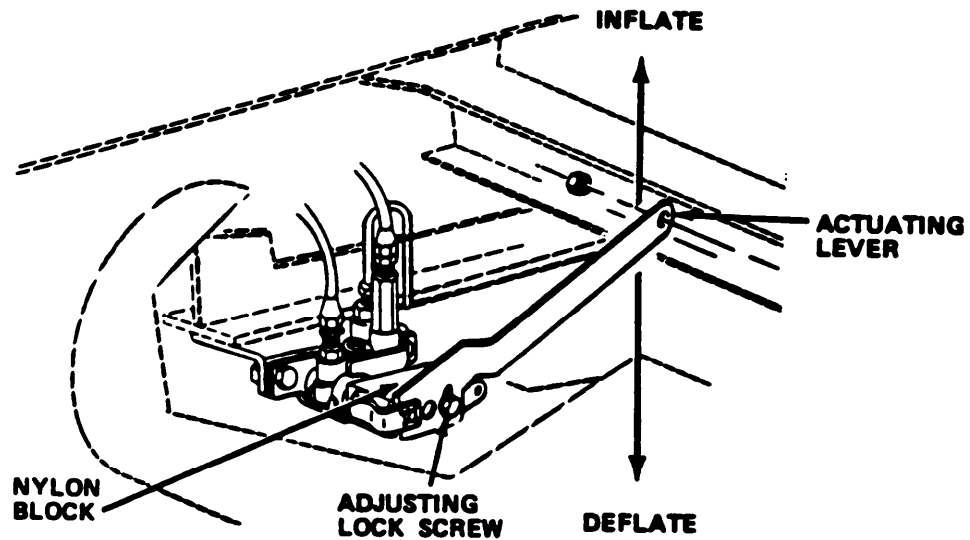

9. Loosen adjustment screw and move nylon block (up or down until desired frame-to-axle height is achieved (4.4.1.23)
10. Tighten adjustment screw securely.
11. Check fittings for leaks by applying soapy water solution and inspecting for presence of bubbles.

4.4.1.25 REPLACE AIR HOSES.

TOOLS: Combination Wrench Set

SUPPLIES: Hoses  
Liquid Detergent  
Plastic Pail

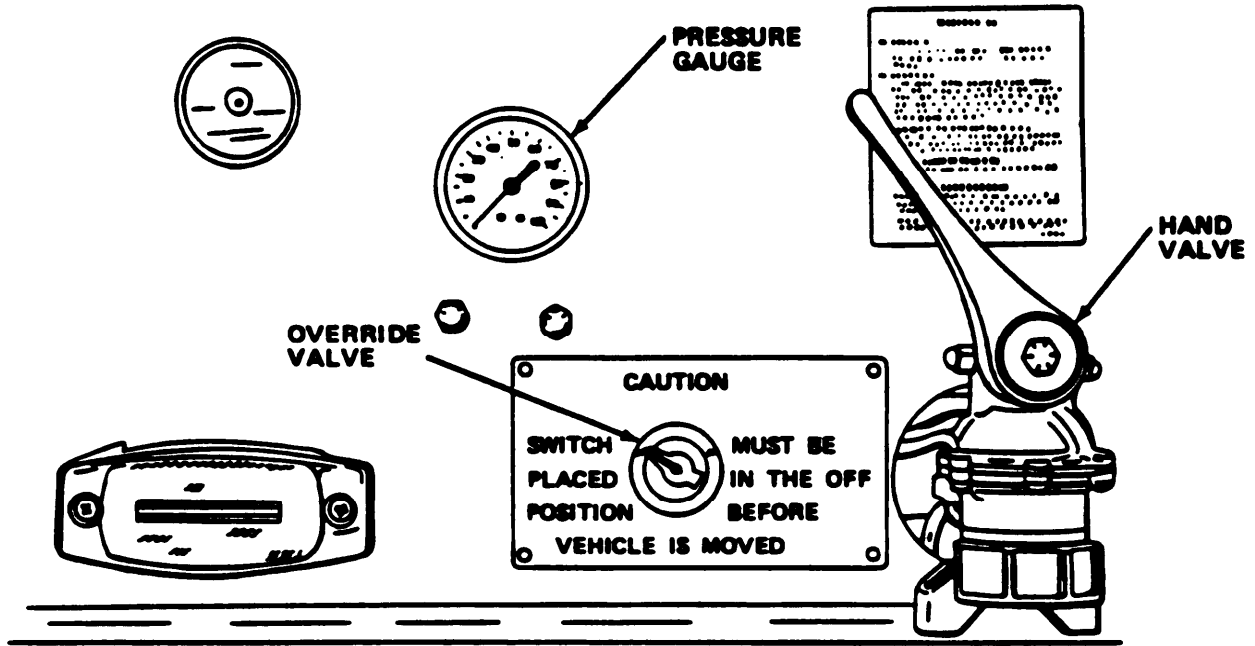

1. Depressurize air system by opening ejector.

Male pipe end of air hose does not swivel. To remove the male end of an air hose from a component, disconnect the swivel at the other end of the air line. Then disconnect the air line from the chassis so that the male pipe end turns freely.

2. Loosen connectors and remove hose.
3. Remove hose tag by prying apart enough to slip over connector.
4. Remove retaining clips and hose from chassis.
5. Install new hose to chassis and retain with clips.



6. Reinstall hose tag.
7. Install new hose and tighten securely.
8. Repressurize air system.
9. Check fittings for leaks by applying soapy water solution and inspecting for presence of bubbles.

#### 4.4.1.26 REPLACE HUBODOMETER.

TOOLS: Tool Kit,

SUPPLIES: Hubodometer

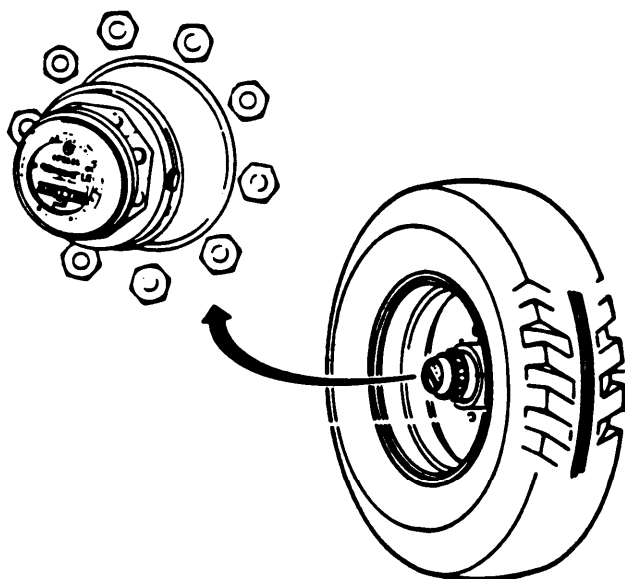

1. Remove hubcap.
2. Remove nut and washer which secures hubodometer to hubcap.
3. Secure new hubodometer to hubcap with nut and washer.
4. Replenish any grease that leaked out while hubcap was off.
5. Reinstall hubcap.

Section IV. PREPARATION FOR STORAGE OR SHIPMENT

4.5.1 PREPARATION FOR STORAGE OR SHIPMENT In the event individual items of equipment must be removed from the section for repair or replacement, contact your battalion for packing and shipping instructions.

**CHAPTER 5****DIRECT/GENERAL SUPPORT MAINTENANCE INSTRUCTIONS****Section I. REPAIR PARTS, SPECIAL TOOLS, AND EQUIPMENT****5.1.1 REPAIR PARTS & SPECIAL TOOLS; TEST, MEASUREMENT, AND DIAGNOSTIC EQUIPMENT; AND SUPPORT EQUIPMENT**

5.1.1.1 COMMON TOOLS AND EQUIPMENT. For authorized common tools and equipment, refer to the Modified Table of Organization and Equipment (MTOE) applicable to your unit.

5.1.1.2 SPECIAL TOOLS; TEST, MEASUREMENT, AND DIAGNOSTIC EQUIPMENT; AND SUPPORT EQUIPMENT. Special tools; test, measurement, and diagnostic equipment; and support equipment required for the repair of this equipment are found in the Repair Parts and Special Tools List (RPSTL). (5.1.1.3)

5.1.1.3 REPAIR PARTS. Repair parts for this equipment are listed in TM5-2330-305-24P, Repair Parts and Special Tools List (RPSTL), covering Organizational and Direct/General Support maintenance for this equipment.

**Section II. TROUBLESHOOTING**

5.2.1 TROUBLESHOOTING. There are no specific instructions for troubleshooting at the Direct/General Support Maintenance level. Refer to Table 4-2 in Organizational Maintenance to isolate any malfunctions.

**Section III. MAINTENANCE INSTRUCTIONS**

5.3.1 MAINTENANCE procedures This section contains the step-by-step procedures for performing Direct/General Support Maintenance for the Chassis, Semitrailer. Personnel required are listed only if the task requires more than one. If personnel are not listed, it means one person can do the task.

5.3.2 GENERAL There are no procedures for the removal and installation of the major components and assemblies which are the responsibility of Direct/General Support maintenance. All major components or assemblies require disassembly during repair and are not included in this section.

INDEX

Procedures	PARAGRAPH
Repair Landing Gear Assembly . . . . .	.5.3.2.1
Replace Cam Bearing . . . . .	.5.3.2.2
Replace Brakes . . . . .	.5.3.2.3
Repair Leveling Jack. . . . .	.5.3.2.4
Replace Bearing/Seal s . . . . .	.5.3.2.5
Replace Hub/Drum Assembly . . . . .	.5.3.2.6
Replace Air Tank . . . . .	.5.3.2.7

5.3.2.1 REPAIR LANDING GEAR ASSEMBLY.

TOOLS: Tool Kit

SUPPLIES: Cleaning Solvent  
Gear Grease

CAUTION

BE SURE CHASSIS IS PARKED ON LEVEL GROUND AND IS UNHOOKED FROM TRUCK BEFORE PROCEEDING TO PREVENT PERSONNEL INJURY.

1. Remove landing gear assembly from chassis. (4.4.1.10)
2. Remove nut and bolt which secure handle to gearbox shaft. Remove handle.
3. Remove six nuts and six bolts which secure gearbox cover. Remove gearbox . cover.
4. Remove two gearbox shaft bearings.

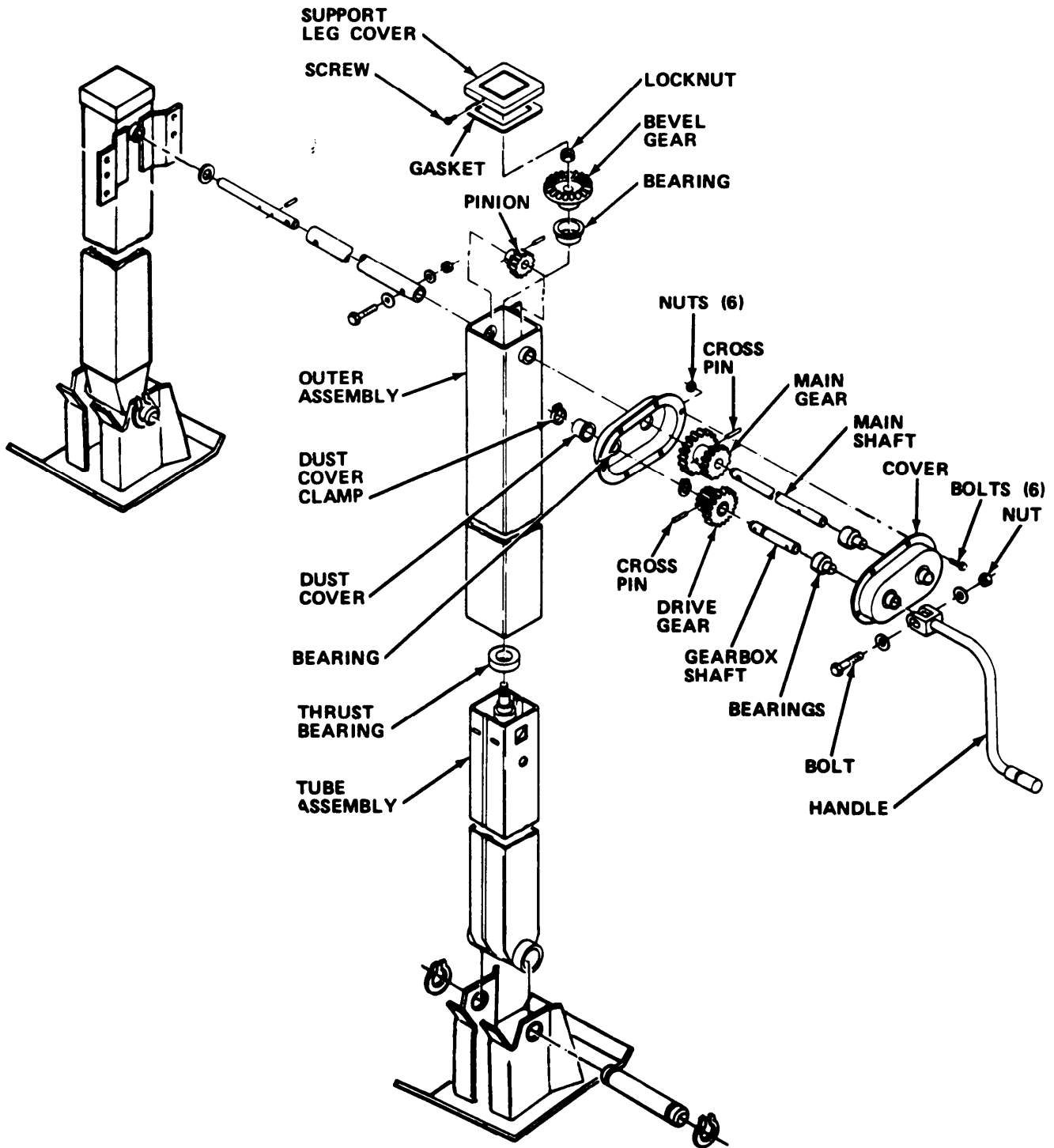

5. Using a drift pin punch, remove two cross pins which secure main gear to main shaft and drive gear to gearbox shaft. Remove gears.
6. Remove dust cover clamp and dust cover from inboard end of gearbox shaft.
7. Remove detent spring from gearbox shaft.
8. Remove gearbox shaft and bearing.
9. Remove screw, support leg cover and cover gasket.
10. Remove main shaft and pinion.
11. Remove lock nut which secures bevel gear to worm screw shaft. Remove bevel gear and bearing.
12. Remove tube assembly by sliding it out of the bottom of leg support outer assembly.
13. Remove thrust bearing from top of tube assembly.

**WARNING**

CLEANING SOLVENT IS POTENTIALLY DANGEROUS. AVOID REPEATED AND PROLONGED SKIN CONTACT AND BREATHING OF VAPORS. USE IN WELL VENTILATED AREA. CLEANING SOLVENT IS TOXIC, VOLATILE AND COMBUSTIBLE.

14. Clean all parts thoroughly with cleaning solvent, until parts are free of dirt and grease.
15. Check all bearings for excessive wear. Check all gears for wear and broken teeth. Check all other parts for excessive wear or damage. When reassembling jack assembly, replace damaged or worn parts.
16. Lubricate thrust bearing with grease and install on top of tube assembly.
17. Lubricate outside portion of tube assembly that slides in leg support outer assembly. Install tube assembly by sliding it in bottom of leg support outer assembly.
18. Install bearing and bevel gear on top of worm screw shaft and secure with lock nut.
19. Install pinion and main shaft.
20. Thoroughly coat bevel gear and pinion with a thick film of gear grease.

21. Install cover gasket and support leg cover. Secure cover to support leg with screw.
22. Install gearbox shaft and bearing, and secure with detent spring.
23. Install dust cover and secure with clamp.
24. Install main gears and drive gear. Secure the gears to their respective shafts with two cross pins.
25. Install two gearbox shaft bearings.
26. Thoroughly coat main gear, drive gear and their bearings with a thick film of gear grease.
27. Install gearbox cover and secure with six nuts and bolts.
28. Install crank handle and secure with nut and bolt. Tighten nut and bolt enough to secure handle, but allow enough slack to ensure handle can be moved.
29. Install landing gear assembly. (4.4.10)

#### 5.3.2.2 REPLACE CAM BEARING.

TOOLS: Brake Pliers  
Ring Pliers

SUPPLIES: Cam Bearing  
Cam Bushing  
Grease

1. Position chassis on level ground (preferably concrete) and uncouple from tractor.

#### WARNING

WHEN JACKING AGAINST AXLE, BE CAREFUL TO USE A JACK WITH A HEAD LARGE ENOUGH TO DISTRIBUTE THE LOAD OR USE WOODEN BLOCK AS A CUSHION BETWEEN THE AXLE AND THE JACK TO PREVENT PERSONNEL INJURY.

2. Chock one wheel opposite the side to be raised to prevent trailer movement. Place jack on a solid foundation to prevent it from slipping out of position, and raise wheel clear of ground.
3. Cage spring brake chamber. (4.4.1.5)

**WARNING**

**DO NOT REMOVE PUSHROD CLEVIS PIN UNLESS BRAKE SPRING CHAMBER IS DISABLED BY CAGING TO PREVENT PERSONNEL INJURY.**

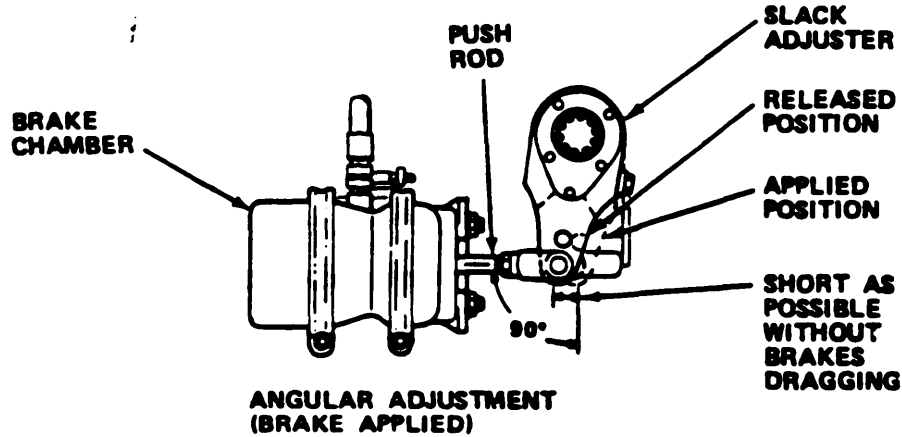

4. Remove clevis pin which secures brake chamber pushrod to slack adjuster.
5. Remove wheel and tire assembly. (4.4.1.1)
6. Remove hub/drum assembly. (5.3.2.6)
7. Remove brake spring and spring retaining pin.
8. Remove brake anchor pin and brake shoe.
9. Remove retaining clip, and slide slack adjuster and cam bushing off end of shaft.
10. Remove retaining clip, and slide camshaft out of housing.
11. Remove cam bearings from housing.

**NOTE**

Before installing cam bearings, ensure they are thoroughly coated with grease MIL-G-10924.

12. Install new cam bearings in housing.
13. Install camshaft in housing and secure with retaining clip.
14. Install cam bushing and slack adjuster, and secure with retaining clip.



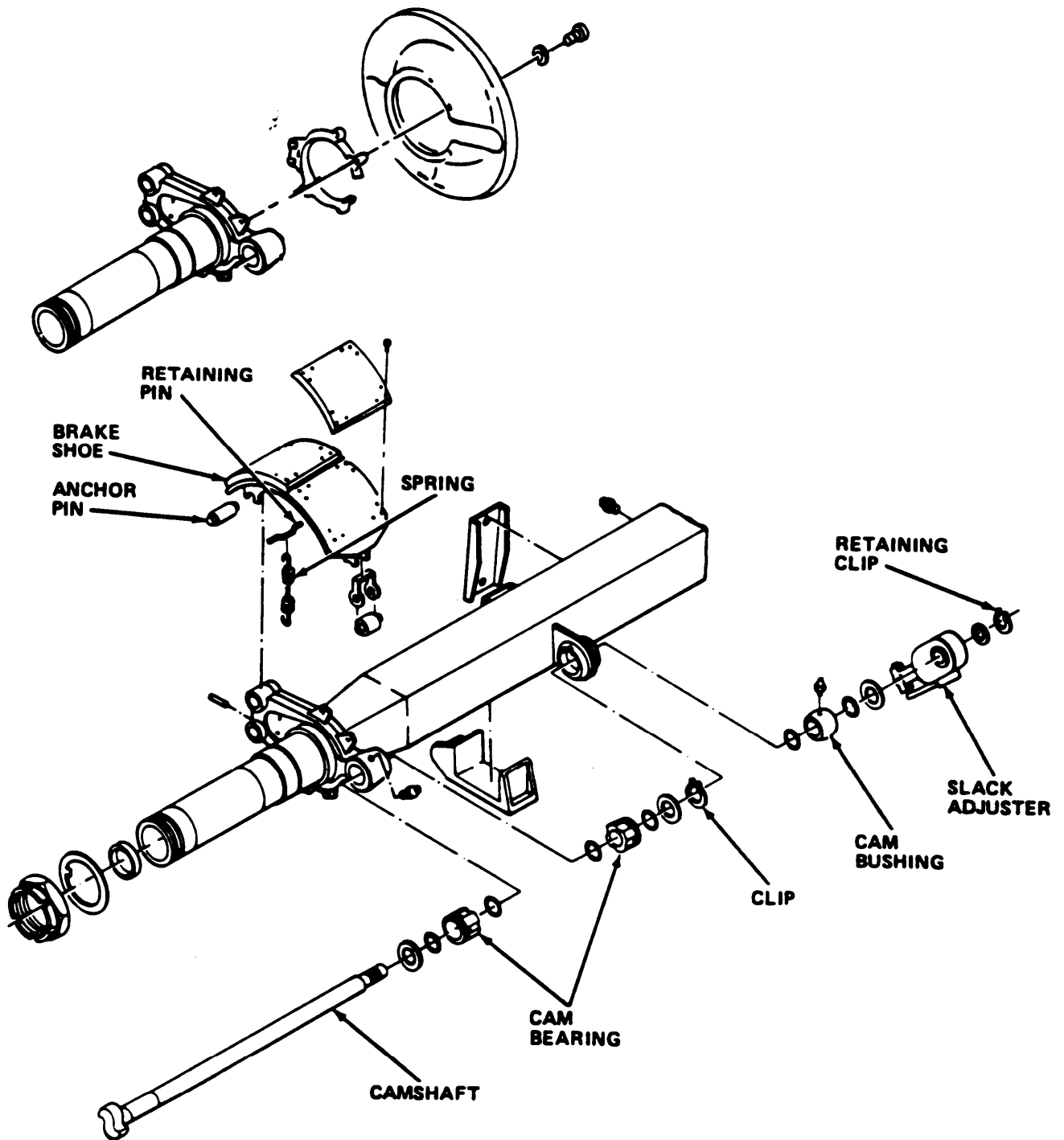

**CAUTION**

WHEN APPLYING GREASE TO CAM ROLLER SURFACE, ENSURE THAT NO EXCESS GREASE COMES IN CONTACT WITH BREAKING SURFACES.

15. Apply a thin film of grease MIL-G-10924 to the cam roller surface.

16. Install brake shoe and secure with brake anchor pin.
17. Install spring retaining pin and brake spring.
18. Install wheel and drum assembly. (5.3.2.6)
19. Install clevis pin which secures brake chamber pushrod to slack adjusters.
20. Uncage brake spring chamber. (4.4.1.5)
21. Adjust brakes. (4.4.1.21)
22. Lower wheel and remove wheel chocks.

**Warning**

TO PREVENT INJURY TO PERSONNEL BE SURE CHASSIS IS PARKED ON LEVEL GROUND AND IS UNHOOKED FROM TRAILER PROCEEDING

2. Remove wheel and tire assembly (4.4.1.21).
3. Cage spring brake chamber (4.4.1.13).

**Warning**

DO NOT REMOVE PUSHROD CLEVIS PIN UNLESS BRAKE CHAMBER IS DISABLED BY CAGING TO PREVENT PERSONNEL INJURY.

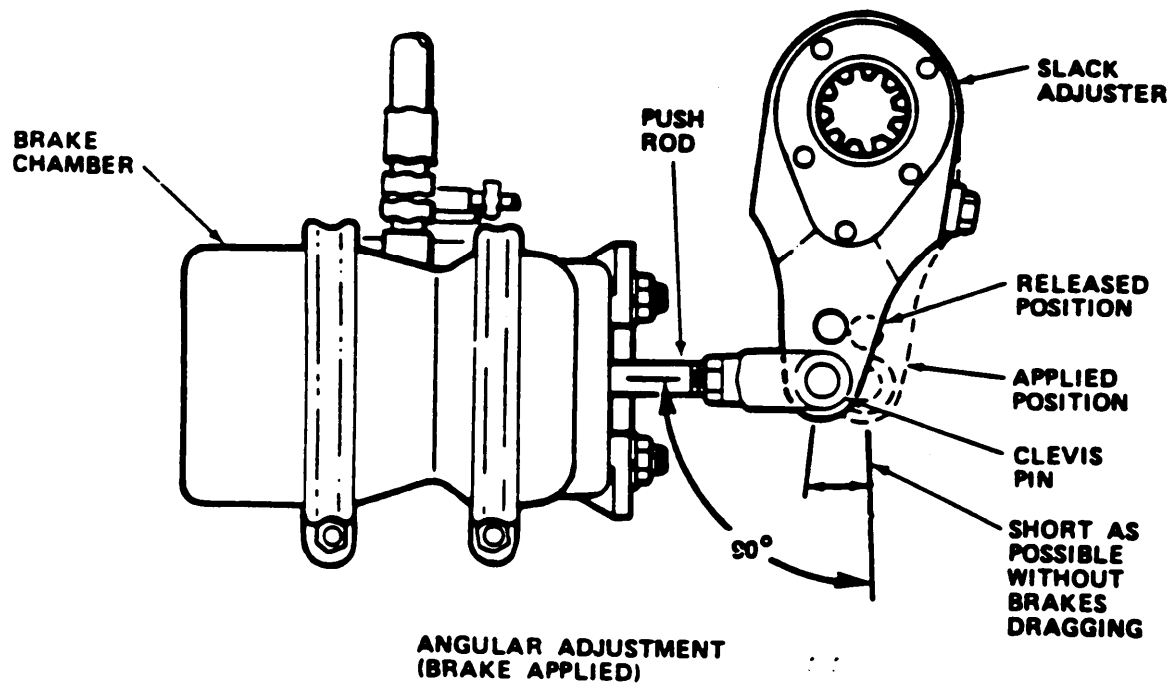

4. Remove clevis pin which secures brake chamber pushrod to slack adjuster.
5. Remove hub/drum assembly (5.3.2.3).

7. Remove brake shoe lining (5.3.2.5).
8. Remove retaining and washer.
9. Remove slack adjuster, washer, O-ring, cam bushing, and O-ring from camshaft.

**NOTE**

When removing camshaft be sure the seals and washers are not lost.

10. Remove retainer ring.
11. Remove camshaft by pulling through cam bracket and brake spider housing retain associated seals and washers.
12. Remove cam bearings

**NOTE**

Before installing cam bearings sure to thoroughly coat with grease, MIL-G-10924.

13. Install cam bearings.
14. Install camshaft and associated seals and washers. Secure with retainer ring.
15. Install cam bushing and associated O-rings and washer.
16. Install slack adjuster and secure with washer and retainer ring.

5.2.2.4 REPAIR LEVELING JACK.

TOOLS: Combination Wrench (9/16 in.)  
Combination Wrench (7/16 in.)  
Adjustable Wrench (8 in.)  
Pin Punch  
Ball Peen Hammer

SUPPLIES: Cleaning Solvent  
Gear Grease

**CAUTION**

BE SURE CHASSIS IS PARKED ON LEVEL GROUND  
AND IS UNHOOKED FROM TRUCK BEFORE PROCEED-  
ING TO PREVENT PERSONNEL INJURY.

1. Remove jack assembly from chassis. (4.4.10)
2. Remove nut and bolt which secure handle to gearbox shaft. Removed handle.
3. Remove six nuts and six bolts which secure gearbox cover. Remove gearbox cover.
4. Remove two gearbox shaft bearings.
5. Using adrift pin punch, remove two cross pins which secure main gear to main shaft and drive gear to gearbox shaft. Remove gears.
6. Remove dust cover clamp and dust cover from Inboard end of gearbox shaft.
7. Remove detent spring from gearbox shaft.
8. Remove gearbox shaft and bearing.
9. Remove screw, support leg cover and cover gasket.
10. Remove main shaft and pinion.
11. Remove lock nut which secures bevel gear to worm screw shaft. Remove bevel gear and bearing.
12. Remove tube assembly by sliding it out of the bottom of leg support outer assembly.
13. Remove thrust bearing from top of tube assembly.

10. Drill out rivets which secure brake pads to shoe and remove pads.
11. Position new brake pads on brake shoe and clamp in place with C-clamps.

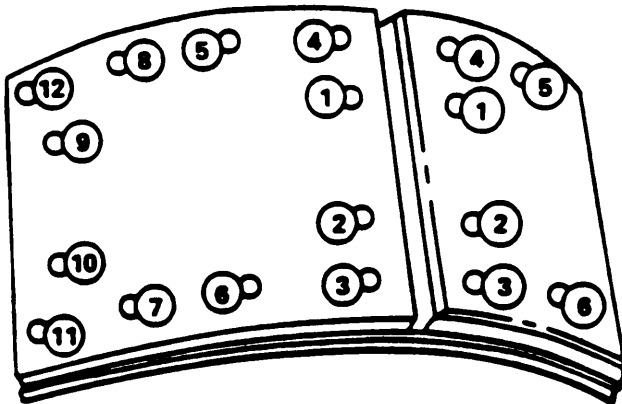

12. Install new rivets in the sequence shown in change to fit.
13. Install brake shoe roller on brake shoe and secure with retainer.
14. Install brake shoe and secure with brake anchor pin.
15. Install spring retaining pin and brake spring.
16. Install hub/drum assembly. (5.3.2.6)
17. Install heel and tire assembly. (4.4.1.1)
18. Secure brake chamber pushrod to slack adjuster with clevis pin.
19. Uncage brake spring chamber. (4.4.1.5)
20. Adjust brakes. (4.4.1.21)
21. Lower wheel and remove wheel chocks.

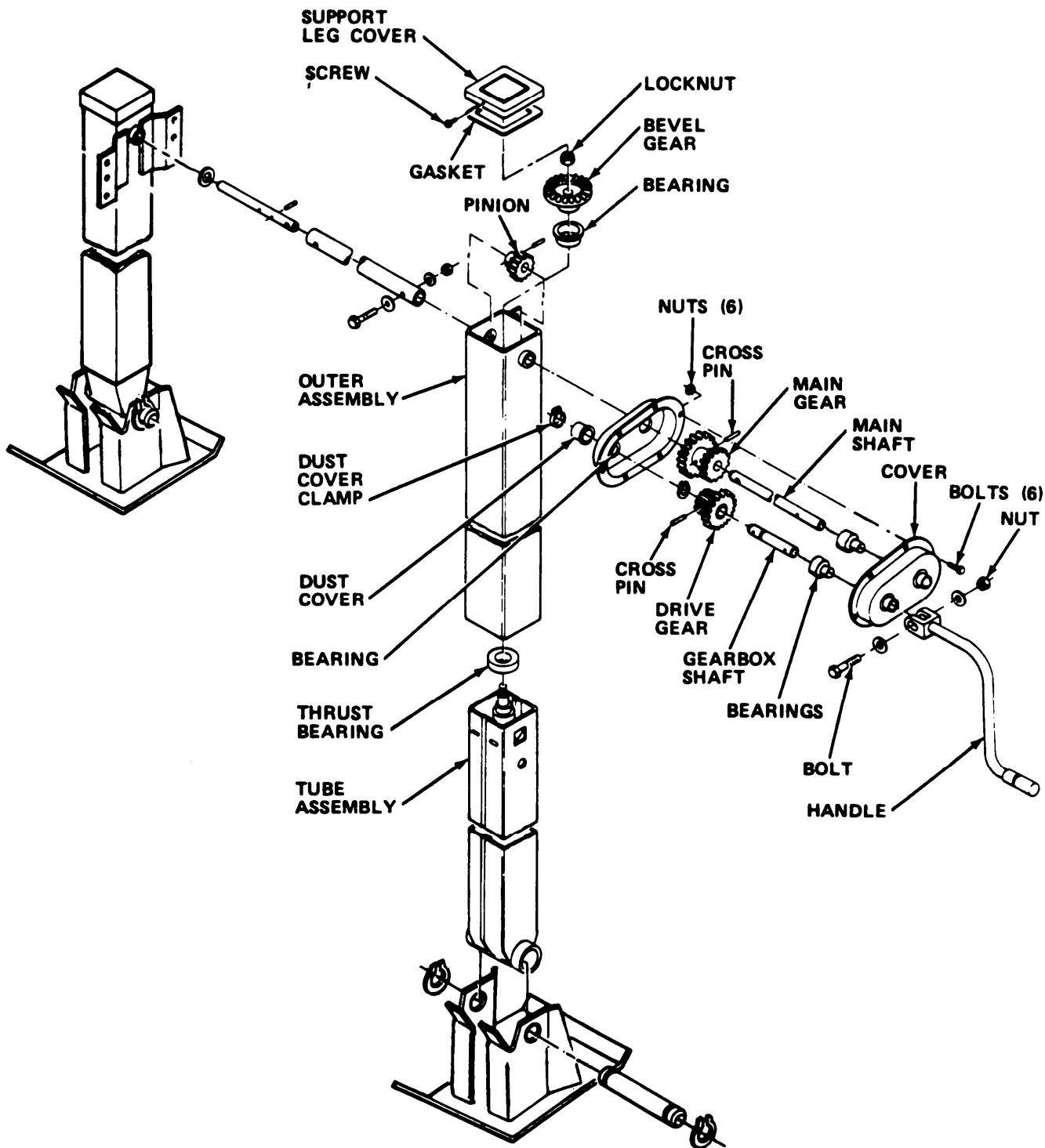

**WARNING**

CLEANING SOLVENT IS POTENTIALLY DANGEROUS. AVOID REPEATED AND PROLONGED SKIN CONTACT AND BREATHING OF VAPORS. USE IN WELL VENTILATED AREA CLEANING SOLVENT IS TOXIC, VOLATILE AND COMBUSTIBLE.

14. Clean all parts thoroughly with cleaning solvent, until parts are free of dirt and grease.
15. Check all bearings for excessive wear. Check all gears for wear and broken teeth. Check all other parts for excessive wear or damage. When reassembling jack assembly, replace damaged or worn parts.
16. Lubricate thrust bearing with grease and install on top of tube assembly.
17. Lubricate outside portion of tube assembly that slides in leg support outer assembly. Install tube assembly by sliding it in bottom of leg support outer assembly.
18. Install bearing and bevel gear on top of worm screw shaft and secure with lock nut.
19. Install pinion and main shaft.
20. Thoroughly coat bevel gear and pinion with a thick film of gear grease.
21. Install cover gasket and support leg cover. Secure cover to support leg with screw.
22. Install gearbox shaft and bearing, and secure with detent spring.
23. Install dust cover and secure with clamp.
24. Install main gears and drive gear. Secure the gears to their respective shafts with two cross pins.
25. Install two gearbox shaft bearings.
26. Thoroughly coat main gear, drive gear and their bearings with a thick film of gear grease.
27. Install gearbox cover and secure with six nuts and bolts.
28. Install crank handle and secure with nut and bolt. Tighten nut and bolt enough to secure handle, but allow enough slack to ensure handle can be moved.
29. Install jack assembly. (4.4.1.10)



5.3.2.5 REPLACE BEARING/SEALS.

TOOLS : Wrench Set  
 Flat-Tipped Screwdriver (1/4 in.)  
 Slip Joint Pliers  
 Bearing Puller

SUPPLIES: Bearing Cup  
 Bearing  
 Wheel Seal  
 Cotter Pin  
 Cap O-Ring

1. Remove hub/drum assembly. (5.3.2.6)

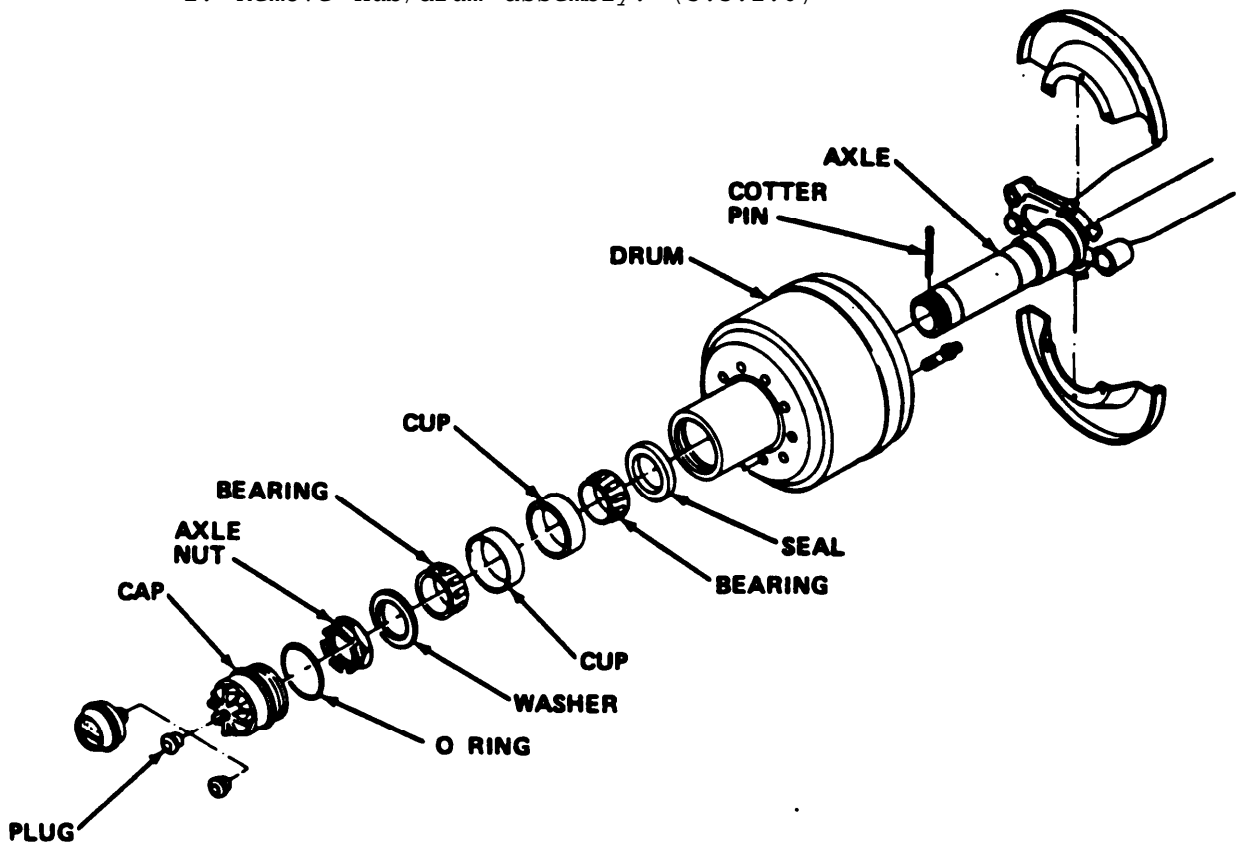

2. Pry rear seal out of rear of hub/drum assembly. Remove bearing washer.
3. Slide bearings out both ends of hub/drum assembly. Drive out old bearing cups.
4. Place a coat of oil over new bearings and bearing cups.
5. Press on bearing cups in each end of assembly. Insert bearings.
6. Press new rear seal into rear of assembly, in front of bearing.

CAUTION

DO NOT PRESS (ON OR PRY NEW SEAL WITH SHARP OR POINTED TOOLS TO PREVENT DAMAGE TO SEAL.

7. Slide hub/drum assembly onto axle shaft.
8. Slide on bearing washer.
9. Screw axle nut onto shaft until first few threads engage. While holding axle nut immobile, spin wheel left. Spin wheel until axle nut is screwed completely on shaft and wheel cannot be spun any more. Back axle nut off 1/4 turn.
10. Insert new cotter pin and fasten.
11. Place new O-ring and axle cap on end of shaft.
12. Fill bearing cavity and cap with oil up to fill mark.
13. Put center plug in cap.

5.3.2.6 REPLACE HUB/DRUM ASSEMBLY.

TOOLS: Wrench Set  
Flat-Tipped Screwdriver (1/4 in.)  
Slip-Joint Pliers  
Bearing Puller

SUPPLIES: Hub/Drum  
Bearing Cup  
Bearing  
Wheel Seal  
Cotter Pin  
Cap O-Ring

**WARNING**

ENSURE THAT CHASSIS IS PARKED ON LEVEL GROUND.

CAUTION

ENSURE THAT BRAKE SPRING IS CAGED OR DAMAGE TO EQUIPMENT WILL RESULT.

1. Remove wheel. (4.4.1.1)
2. Cage spring brake chamber. (4.4.1.5)

3. Drain oil from axle bearing. If wheel has hubodometer mounted, remove hubodometer housing.

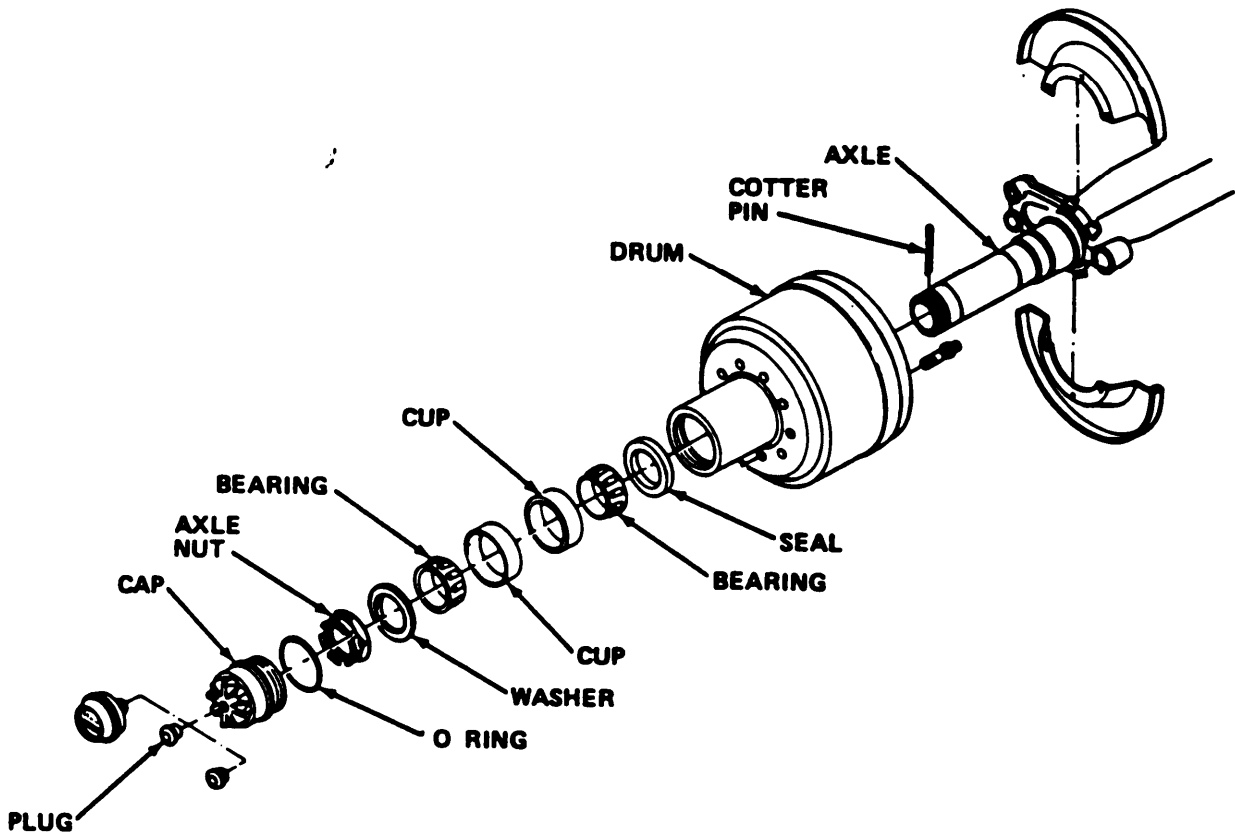

4. Pull off hub cap and O-ring.
5. Remove cotter pin in end of axle shaft.

#### NOTE

Axle nut has left-hand threads.

6. Remove axle nut and bearing washer.
7. Slide hub/drum assembly off axle.
8. Pry rear seal out of rear of assembly.
9. Slide bearings out ends of old hub/drum assembly. Inspect for pits, cavities, scratches or other signs of wear. Replace bearings are worn.
10. Slide bearings into cups in new hub/drum assembly. If bearings are new, put a thin coat of oil on bearing before inserting.

11. Slide new rear seal into rear of assembly.
12. Slide new hub/drum assembly and bearings onto axle shaft.
13. Slide on bearing washer.
14. Screw axle nut on shaft until the first few threads have engaged.  
Spin wheel left while holding axle nut stationary. Spin wheel until nut is completely on shaft and wheel cannot be spun anymore. Back axle nut off 1/4 turn.
15. Insert new cotter pin and fasten.
16. Place new O-ring and axle cap on end of shaft.
17. Fill bearing cavity and cap with oil up to the full mark.
18. Put center plug into cap.
19. Replace wheel.
20. Remove brake spring cage.

5.3.2.7 REPLACE AIR TANK.

TOOLS: Combination Wench (9/16 in.)  
Reservoir

SUPPLIES: Thread Sealant (TFL)  
Liquid Detergent  
Plastic Pail  
Cotton Cloth  
Solvent  
Air Tank

1. Remove van body.
2. Repressurize air system by opening moisture ejector.
3. Remove relay quick release valve (4.4.1.3).
4. Remove ratio relay valve (4.4.1.2).
5. Loosen fitting and remove air hose.
6. Remove four nuts, bolts and washers retaining tank to frame brackets.
7. Remove moisture ejector from bottom of tank.
8. Remove tank from frame brackets.
9. Install new tank to frame brackets.

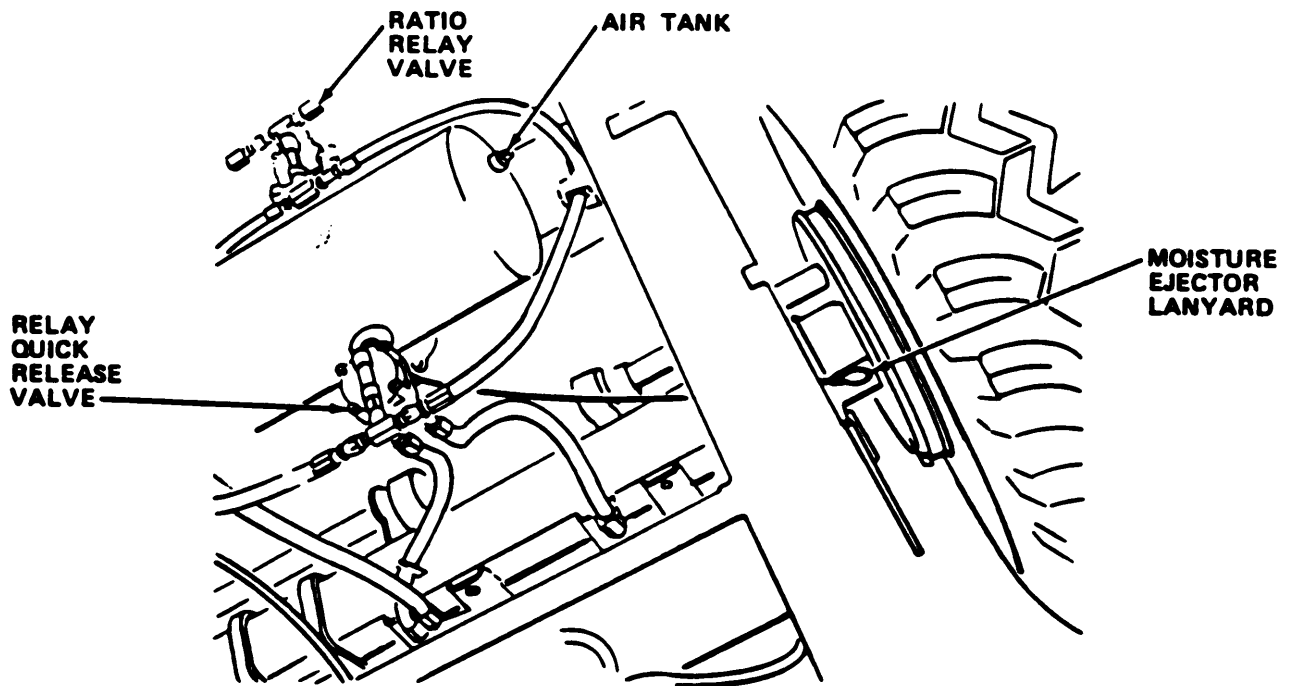

10. Clean all fittings with solvent-saturated, cotton cloth.

**CAUTION**

DO NOT ALLOW SEALANT TO ENTER AIR SYSTEM.

11. Apply sealant to threads and reinstall moisture ejectors.
12. Reinstall retaining bolts, nuts and washers, and tighten securely.
13. Reinstall air hose and tighten fitting securely.
14. Reinstall ratio relay valve.
15. Reinstall ratio quick release valve.
16. Pressurize air system and check for leaks by applying a soapy water solution to fittings and inspecting for the presence of bubbles.



**APPENDIX A**

**REFERENCES**

**A-1. SCOPE.** This appendix lists all forms, technical manuals and other publications referenced in this manual, as well as other pertinent information.

**A-2. PUBLICATION INDEX.** The following index should be consulted frequently for the latest changes or revisions and for new publications relating to the material covered in this technical manual.

Consolidated Index of Army Publications and Blank Forms . . . . . DA PAM 310-1

**A-3 FORMS.** Refer to TM 38-750 -- The Army Maintenance Management System (TAMMS) for instructions on the use of maintenance forms pertaining to this material.

Recommended Changes to Publications and Blank Forms . . . . . DA Form 2028

Recommended Changes to Equipment Technical Publications . . . . . DA Form 2028-2

Hand Receipt/Annex Number. . . . . DA Form 2062

Equipment Inspection and Maintenance Worksheet . . . . . DA Form 2404

Quality Deficiency Report . . . . . SF-368

**A-4. TECHNICAL MANUALS**

Administrative Storage of Equipment . . . . . TM 740-90-1

Procedures for Destruction of Equipment to Prevent  
Enemy Use. . . . . TM 750-244-3

Organizational, Direct Support and General Support  
Maintenance Repair Parts and Special Tools List  
(Including Depot Maintenance Repair Parts and  
Special Tools) for Chassis, Semi-Trailer,  
Container Transporter (ADCOR) . . . . . TM 5-2330-305-24P

Hand Receipt Covering Contents of Components of End  
Item (COEI), Basic Issue Items (BII) and Additional  
Authorization List (AAL) for Chassis, Semi-Trailer;  
Container Transporter (ADCOR) . . . . . TM 5-2330-305-14-HR

Lubrication Order for Chassis, Semi-Trailer . . . . . LO 5-2330-305-12

**A-5. MISCELLANEOUS PUBLICATIONS.** The following Technical Bulletins, Technical Manuals and Field Manuals contain information pertinent to the major items of hardware and/or accessory equipment for the Chassis, Semi-trailer transporter.

a. Maintenance and Repair

- Organizational Care, Maintenance and Repair of  
Pneumatic Tires, Inner Tubes and Radial Tires . . . . . TM 9-2610-200-20
- Metal Body Repair and Related Operations . . . . . FM43-2
- Welding Theory Application . . . . . TM 9-237
- Painting Instructions for Field Use . . . . . TM 43-0139
- Inspection, Care and Maintenance of Antifriction  
Bearings . . . . . TM-214

b. Cold Weather Operation and Maintenance

- Basic Cold Weather Manual . . . . . FM 31-70
- Northern Operations. . . . . FM 31-71
- Operation and Maintenance of Ordnance Material in  
Extreme Cold Weather (0 to -65 F -- -18 to -54 C) . . . . . TM 9-207

c. Decontamination

- Chemical, Biological and Radiological (CBR)  
Decontamination. . . . . TM 3-220
- Nuclear, Biological and Chemical (NBC) Defense  
Reprinted with Basic Incl. C1) . . . . . FM 21-40

d. General

- Camouflage . . . . . FM 5-20
- Use and Care of Hand Tools and Measuring  
Tools... . . . . TM 9-243



## APPENDIX B

## MAINTENANCE ALLOCATION CHART

## Section I. INTRODUCTION

**B-1. GENERAL**

a. This section provides a general explanation of all maintenance and repair functions authorized at various maintenance categories.

b. The Maintenance Allocation Chart (MAC) in Section II designates overall responsibility for the performance of maintenance functions on the identified end item or component. The implementation of maintenance functions upon the end item or component will be consistent with the assigned maintenance functions.

c. Section III lists the special tools and test equipment required for each maintenance function as referenced from Section.

d. Section IV contains supplemental instructions and explanatory notes for a particular maintenance function.

**B-2. MAINTENANCE FUNCTIONS.** Maintenance functions will be limited to and defined as follows:

a. **INSPECT.** To determine the serviceability of an item by comparing its physical, mechanical and/or electrical characteristics with established standards through examination.

b. **TEST.** To verify serviceability by measuring the mechanical or electrical characteristics of an item and comparing those characteristics with prescribed standards.

c. **SERVICE.** Operations required periodically to keep an item in proper operating condition, i.e., to clean (includes decontaminate, when required), preserve, drain, paint, or replenish fuel, lubricants, chemical fluids, or gases.

d. **ADJUST.** To maintain, within prescribed limits, by bringing into proper or exact position or by setting the operating characteristics to specified parameters.

e. **ALIGN.** To adjust specified variable elements of an item to bring about optimum or desired performance.

f. **CALIBRATE.** To determine and cause corrections to be made or to be adjusted on instruments or test, measuring and diagnostic equipment used in precision measurement. Consists of comparisons of two instruments; one of which is a certified standard of known accuracy, to detect and adjust any discrepancy in the accuracy of the instrument being compared.

g. **INSTALL.** The act of emplacing, seating, or fixing into position an item, part or module (component or assembly) in a manner to allow the proper functioning of an equipment or system.

h. REPLACE. The act of substituting a serviceable like-type part, subassembly or module (component or assembly) for an unserviceable counterpart.

i. REPAIR. The application of maintenance services, including fault location troubleshooting<sup>2</sup>, removal/installation, and disassembly/assembly procedures, and maintenance actions<sup>4</sup> to identify troubles and restore serviceability to an item by correcting specific damage, fault, malfunction, or failure in a part, subassembly, module (component or assembly), end item or system.

j. OVERHAUL. That maintenance effort (service/action) necessary to restore an item to a completely serviceable/operational condition as prescribed by maintenance standards in appropriate technical publications (i.e., DMWR). Overhaul is normally the highest degree of maintenance performed by the Army. Overhaul does not normally return an item to like-new condition.

k. REBUILD. Consists of those services/actions necessary for the restoration of unserviceable equipment to a like-new condition in accordance with original manufacturing standards. Rebuild is the highest degree of material-maintenance applied to Army equipment. The rebuild operation includes the act of returning to zero those age measurements (hours/miles, etc) considered in classifying Army equipment/components.

### **B-3 EXPLANATION OF COLUMNS IN THE MAC, SECTION II**

a. COLUMN (1): GROUP NUMBER. Column (1) lists functional group code numbers, the purpose of which is to identify maintenance significant components, assemblies, subassemblies and modules with the next higher assembly. End item group number shall be "00."

b. COLUMN (2): COMPONENT/ASSEMBLY. Column (2) contains the names of components, assemblies, subassemblies, and modules for which maintenance is authorized.

c. COLUMN (3): MAINTENANCE FUNCTION. Column (3) lists the functions to be performed on the item listed in Column (2). (For detailed explanation of these functions, see paragraph B-2.)

<sup>1</sup>Services - Inspect, test, service, adjust, align, calibrate and/or replace.

<sup>2</sup>Fault Locate/troubleshoot - The process of investigating and detecting the cause of equipment malfunctioning; the act of isolating a fault within a system or unit under test (UUT).

<sup>3</sup>Disassemble/assemble - Encompasses the step-by-step taking apart (or breakdown) Of a Spare/functional group coded item to the level of its Least componency identified as maintenance significant (i.e., assigned an SMR code) for the category of maintenance under consideration.

<sup>4</sup>Actions - Welding, grinding, riveting, straightening, facing, remachining and/or resurfacing.

d. COLUMN (4): MAINTENANCE CATEGORY. Column (4) specifies, by the listing of a work time figure in the appropriate subcolumn(s), the category of maintenance authorized to perform the function listed in Column (3). This figure represents the active time required to perform that maintenance function at the indicated category of maintenance. If the number or complexity of the tasks within the listed maintenance function varies at different maintenance categories, appropriate work time figures will be shown for each category. The work time figure represents the average time required to restore an item [assembly, subassembly, component, module, end item or system) to a serviceable condition under typical field operation conditions. This time includes preparation time (including any necessary disassembly/assembly time), troubleshooting/fault location time, and quality assurance/quality control time in addition to the time required to perform the specific tasks identified for the maintenance functions authorized in the Maintenance Allocation Chart. The symbol designations for the various maintenance categories are as follows:

C	Operator or Crew
O	Organizational Maintenance
F	Direct Support Maintenance
H	General Support Maintenance
D	Depot Maintenance

e. COLUMN (5): TOOLS AND EQUIPMENT. Column (5) specifies by code those common tool sets (not individual tools) and special tools, TMDE and support equipment required to perform the designated function.

f. COLUMN (6): REMARKS. This column shall, when applicable, contain a letter code, in alphabetical order, which shall be keyed to the remarks contained in Section IV.

#### B-4. EXPLANATION OF COLUMNS IN TOOL AND TEST EQUIPMENT REQUIREMENTS, SECTION III

a. COLUMN (1): REFERENCE CODE. The tool and test equipment reference code correlates with a code used in the MAC, Section II, Column (5).

b. COLUMN (2): MAINTENANCE CATEGORY. The lowest category of maintenance authorized to use the tool or test equipment.

c. COLUMN (3): NOMENCLATURE. Name or identification of the tool or test equipment.

d. COLUMN (4): NATIONAL STOCK NUMBER. The National stock number of the tool or test equipment.

e. COLUMN (5): TOOL NUMBER. The manufacturer's part number.

**B-5. EXPLANATION OF REFERENCE CODES, SECTION IV**

- a. COLUMN (1): REFERENCE CODE. The code recorded in Column (6), Section II.
- b. COLUMN (2): REMARKS. This column lists information pertinent to the maintenance function being performed as indicated in the MAC, Section II.

Section II: MAINTENANCE ALLOCATION CHART

(1) GROUP NUMBER	(2) COMPONENT/ASSEMBLY	(3) MAINTENANCE FUNCTION	(4) MAINTENANCE CAT					(5) TOOLS AND EQPT	(6) REMARKS
			C	O	F	H	D		
00	CHASSIS	Inspect Remove/ Install Repair	.08	.05 1.0					
01	CHASSIS, SEMITRAILER	Inspect Remove/ Install Adjust	1.0	.25 6.55				7 12 51 3 5 9 12 22 25 26 31 33 37 42 51 52	
	JACK, LEVELING, FRONT	Repair Inspect Replace	1.0 .25	1.0 .66					
		Repair			3.47			17 18 20 2 6 16 18 26 28 36	
	JACK, LEVELING REAR	Inspect Replace Repair		.25 .66					
		Repair			3.47			17 18 20 2 6 16 18 26 28 36	
	LANDING GEAR ASSY	Inspect Replace Repair		.25 1.95					
		Repair			3.47			17 18 20 2 6 16 18 26 28 36	

Section II. MAINTENANCE ALLOCATION CHART (CONT)

(1) GROUP NUMBER	(2) COMPONENT/ASSEMBLY	(3) MAINTENANCE FUNCTION	(4) MAINTENANCE CAT					(5) TOOLS AND EQPT	(6) REMARKS
			C	O	F	H	D		
	LIGHTS/WIRING ASSY	Inspect Repair	.31	2.2				35	
	PNEUMATIC ASSY								
	OVERRIDE ASSY	Inspect Repair		.18 2.68				12 51 3 12 21 22 23 24 26 31 34 51	
	AIR RIDE ASSY	Inspect Adjust Repair		.70 .50 1.25				12 51 48 12 25 48 51	
	EJECTOR ASSY MOISTURE	Service Replace	.25	.50				1 31	
	HITCH COMPONENT ASSY	Inspect Repair		.18 2.21				12 51 1 3 12 17 26 31 50 51	
	WHEEL/DRUM, REAR	Replace Repair			1.75 2.00			4 8 32 52	
	AXLE ASSY	Inspect Adjust Repair		.33 2.48				5 6 11 30 49	
	BRAKE ASSY	Inspect Adjust Replace Repair	.25	1.00 2.5	6.0 2.5			4 40 20 6 42 3	

Section II. MAINTENANCE ALLOCATION CHART (Cont)

(1) GROUP NUMBER	(2) COMPONENT/ASSEMBLY	(3) MAINTENANCE FUNCTION	(4) MAINTENANCE CAT					(5) TOOLS AND EQPT	(6) REMARKS
			C	O	F	H	D		
	AIR TANK ASSY	Inspect	.38	.33				10 27 41 46 51	
		Replace			2.68			13 14 15 16 19 29 38 39 40 41 43 44 45 46 47 53	

## TM III. TOOL AND TEST EQUIPMENT REQUIREMENTS

(1) REFERENCE CODE	(2) MAINTENANCE CATEGORY	(3) NOMENCLATURE	(4) NATIONAL/NATO STOCK NUMBER	(5) TOOL NUMBER
1	0	Wrench, Adjustable		AC112
2	0	Hammer, Ball Peen		BP8A
3	0, F	Puller, Bearing		CJ105A
4	0, F	Wrench, Adj, 8 in.		D78
5	C	Gage, Press., Tire Truck		GA246
6	F	Scdr, Flat-Tipped		GGGS121
7	0	Socket, 1-1/4 in.		GTW401
8	0	Wrench, Comb, 1-1/8 in.		OEX36
9	0	Wrench, Comb, 1-5/16 in.		OEX42
10	0	Wrench, Comb, 1-1/2 in.		OEX48
11	0, F	Wrench, Comb, 7/16 in.		OEX140
12	0	Wrench, Comb, 1/2 in.		OEX160
13	0, F	Wrench, Comb, 9/16 in.		OEX180
14	0	Wrench, Comb, 3/4 in.		OEX240
15	0	Wrench, Comb, 15/16 in.		OEX300
16	0	Wrench, Comb, 1/2 in.		OSH16
17	0	Wrench, Comb, 9/16 in.		OSH18
18	0	Wrench, Comb, 11/16 in.		OSH20
19	0	Wrench, Comb, 13/16 in.		OSH22
20	0	Wrench Set, Comb		OSH709K
21	F	Punch, Pin		PPC103C
22	0	Punch, Long, 3/8 pt		PPC912A



## Section III: TOOL AND TEST EQUIPMENT REQUIREMENTS (CONT)

(1) REFERENCE CODE	(2) MAINTENANCE CATEGORY	(3) NOMENCLATURE	(4) NATIONAL/NATO STOCK NUMBER	(5) TOOL NUMBER
23	F	Pliers, Retaining Ring		PR129A
24	F	Wrench Set		SCB61575
25	O	Bar, Breaker		SN24B
26	O	Screwdriver, Flat-Tipped		SSDE42
27	O	Screwdriver, Flat-Tipped, 1/4 in.		SSD4
28	O	Bar, Extension		SX15
29	O	Wrench, Torque		TER2175
30	O	Wrench, Torque		TER352
31	O	Wrench, Torque		TER602
32	O	Wrench, Torque		TER1003
33	O	Wrench, Torque		TE602
34	O	Socket, 3/4 in.		TW241
35	O	Socket, 1 1/8 in.		TW361
36	O	Socket, 1 5/16 in.		TW421
37	O	Socket, 1 1/2 in.		TW481
38	O	Wrench, 1/2 & 9/16 in.		V01618
39	O	Screwdriver, Flat-Tipped		1007
40	F	Pliers, Brake		131A
41	O	Pliers		276
42	O, F	Pliers, Slip Joint		420
43	O	Hammer, 4 lb		90013



## APPENDIX C

## COMPONENTS OF END ITEM AND BASIC ISSUE ITEMS LISTS

## Section I. INTRODUCTION

**C-1. SCOPE** This appendix lists components of end item and basic issue items for the Trailer (ADCOR) Section to help you inventory items required for safe and efficient operation.

**C-2 GENERAL** The Components of End Item and Basic Issue Items Lists are divided into the following sections:

a. SECTION II: COMPONENTS OF END ITEM. This listing is for informational purposes only and is not authority to requisition replacements. These items are part of the end item but are not removed and separately packaged for transportation or shipment. As part of the end item, these items must be with the end item whenever it is issued or transferred between property accounts. Illustrations are furnished to assist you in identifying the items.

b. SECTION III: BASIC ISSUE ITEMS (BII). These are the minimum essential items required to place the Trailer (ADCOR) Section in operation, to operate it and to perform emergency repairs. Although shipped separately packaged, BII must be with the Trailer (ADCOR) Section during operation and whenever it is transferred between property accounts. The illustrations will assist you with hard-to-identify items. This manual is your authority to request/requisition replacement BII based-on TOE/MTOE authorization of the end item

**C-3. EXPLANATION OF COLUMNS** The following provides an explanation of columns found in the tabular listings:

a. COLUMN (1): ILLUSTRATION NUMBER (ILLUS NUMBER). This column indicates the number of the illustration in which the item is shown.

b. COLUMN (2): NATIONAL STOCK NUMBER. Indicates the National stock number assigned to the item and will be used for requisitioning purposes.

c. COLUMN (3): DESCRIPTION Indicates the National item name and, if required, a minimum description to identify and locate the item. The last line for each item indicates the FSCM (in parentheses) followed by the part number.

d. COLUMN (4): UNIT OF MEASURE (U/M). Indicates the measure used in performing the actual operational/maintenance function. This measure is expressed by a two-character alphabetical abbreviation (e.g., ea, in, pr).

e. COLUMN (5): QUANTITY REQUIRED (QTY RQR). Indicates the quantity of the item authorized to be used with/on the equipment.

Section II. Components Of End Item

(1) ILLUS NUMBER	(2) NATIONAL STOCK NUMBER	(3) DESCRIPTION FSCM AND PART NUMBER	(4) U/M	(5) QTY RQR
		Not Applicable		

Section III. BASIC ISSUE

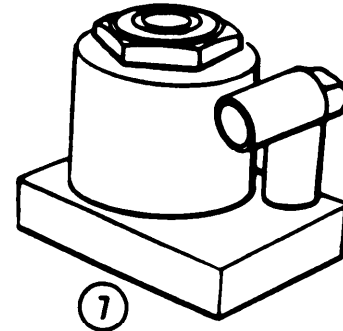
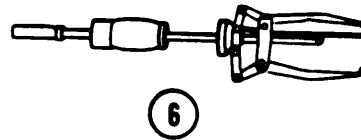
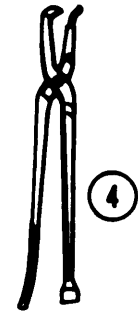
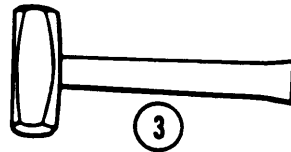
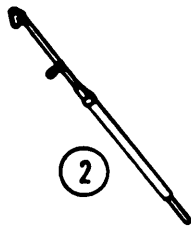

(1) ILLUS NUMBER	(2) NATIONAL STOCK NUMBER	(3) DESCRIPTION FSCM AND PART NUMBER	(4) U/M	(5) QTY RQR
1		(D) Bar, Extension, 15 Inch (28356) SX15	ea	1
2		(D) Gauge, Pressure, Tire (28356) GA246	ea	1
3		(D) Hammer, 4 Lb. (93389) 90013	ea	1
4		(D) Pliers, Brake (28356) 131A	ea	1
5		(D) Pliers, Retaining Ring (28356) PR129A	ea	1
6		(D) Puller, Bearing (28356) CJ105A	ea	1
7		(D) Jack, Hydraulic, 20-Ton (28047) 20.6AA	ea	1

Section III. BASIC ISSUE ITEMS (Cont)

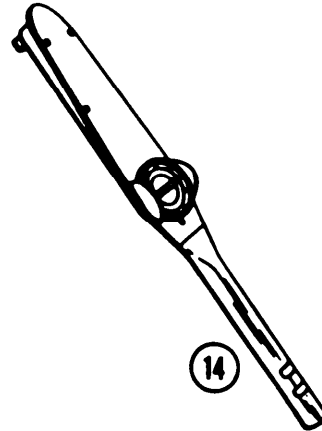
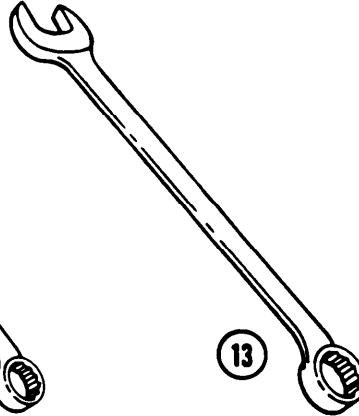
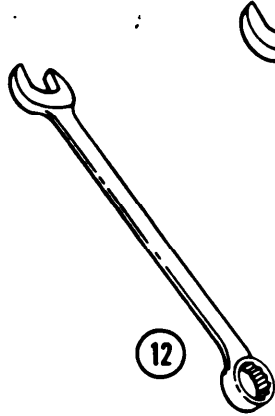
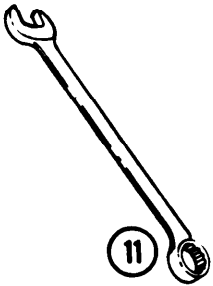
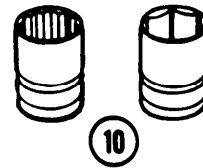
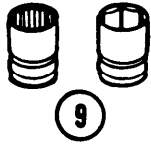
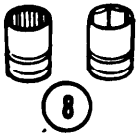

(1) ILLUS NUMBER	(2) NATIONAL STOCK NUMBER	(3) DESCRIPTION FSCM AND PART NUMBER	(4) U/M	(5) QTY RQR
8		(D) Socket, 1-1/8 Inch (28356) TW361	ea	1
9		(D) Socket, 1-5/16 Inch (28356) TW421	ea	1
10		(D) Socket, 1-1/2 Inch (28356) TW481	ea	1
11		(D) Wrench, Combination, 1-1/8 Inch (28356) OEX36	ea	1
12		(D) Wrench, Combination, 1-5/16 Inch (28356) OEX42	ea	1
13		(D) Wrench, Combination, 1-1/2 Inch (28356) OEX48	ea	1
14		(D) Wrench, Torque 0-175 Ft/Lb, 1/2 Inch Square Drive (28356) TER175	ea	1

Section III. BASIC ISSUE ITEMS (Cont)

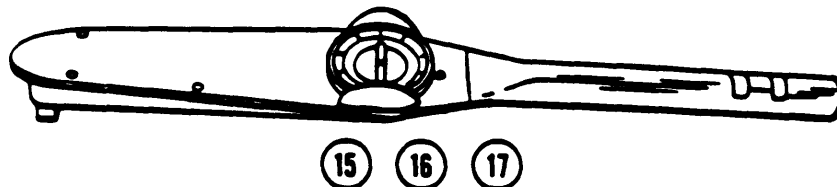

(1) ILLUS NUMBER	(2) NATIONAL STOCK NUMBER	(3) DESCRIPTION FSCM AND PART NUMBER	(4) U/M	(5) QTY RQR
15		(D) Wrench, Torque 0-350 Ft/Lb, 3/4 Inch Square Drive (28356) TER352	ea	1
16		(D) Wrench, Torque 0-600 Ft/Lb, 3/4 Inch Square Drive (28356) TER602	ea	1
17		(U) Wrench, Torque 0-1000 Ft/Lb, 1 Inch Square Drive (28356) TER1003	ea	1





APPENDIX D

ADDITIONAL AUTHORIZATION LIST

Section I. INTRODUCTION

D-1. SCOPE. This appendix lists additional items you are authorized for the support of the Trailer (ADCOR) Section.

D-2 GENERAL. This list identifies items that do not have to accompany the Trailer (ADCOR) and that do not have to be turned in with it. These items are all authorized to you by CTA, MTOE, TDA or JTA.

D-3. EXPLANATION OF LISTING. National stock numbers, descriptions and quantities are provided to help you identify and request the additional items you require to support this equipment. The items are listed in alphabetical sequence by item name.

Section II. ADDITIONAL AUTHORIZATION LIST

(1) NATIONAL STOCK NUMBER	(2) DESCRIPTION  FSCM AND PART NUMBER	(3)  U/M	(4)  QTY AUTH
5180-00-177-7033	(N) Tool Kit, General Mechanic's Automotive (50980) SC5180-90-CL-N26	Kt	1



## APPENDIX E

## EXPENDABLE SUPPLIES AND MATERIALS LIST

## Section I. INTRODUCTION

**E-1. SCOPE.** This appendix lists expendable supplies and materials you will need to operate and maintain the Trailer (ADCOR) Section. These items are authorized to you by CTA 50-970, Expendable Items (except Medical, Class V, Repair Parts and Heraldic Items).

**E-2 EXPLANATION OF COLUMNS**

a. COLUMN (1): ITEM NUMBER. This number is assigned to the entry in the listing and is referenced in the narrative instructions to identify the material (e.g., "Use cleaning compound, Item 5, Appendix D.").

b. COLUMN (2): LEVEL. This column identifies the lowest level of maintenance that requires the listed item.

C	Operator/Crew
O	Organizational Maintenance
F	Direct Support Maintenance
H	General Support Maintenance

c. COLUMN (3): NATIONAL STOCK NUMBER. This is the National stock number assigned to the item. Use it to request or requisition the item.

d. COLUMN (4): DESCRIPTION. Indicates the National item name and, if required, a description to identify the item. The last line for each item indicates the part number followed by Federal Supply Code for Manufacturer (FSCM) in parentheses followed by the part number.

e. COLUMN (5): UNIT OF MEASURE (U/M). Indicates the measure used in performing the actual maintenance function. This measure is expressed by two-character alphabetical abbreviations (e.g., ea, in., pr). If the unit of measure differs from the unit of issue, requisition the lowest unit of issue that will satisfy your requirements.

Section II. EXPENDABLE SUPPLIES AND MATERIALS LISTS

(1) ITEM NUMBER	(2) LEVEL	(3) NATIONAL STOCK NUMBER	(4) DESCRIPTION	(5) U/M
			Not Applicable.	

APPENDIX F

STOWAGE GUIDE

F-1. SCOPE. This appendix shows the locations for stowage of equipment and material.

F-2 GENERAL. The picture below shows the location of signs used in the section. Some are cautions or information you need to operate the section safely. Number callouts refer to the key on the next page.

STOWAGE GUIDE

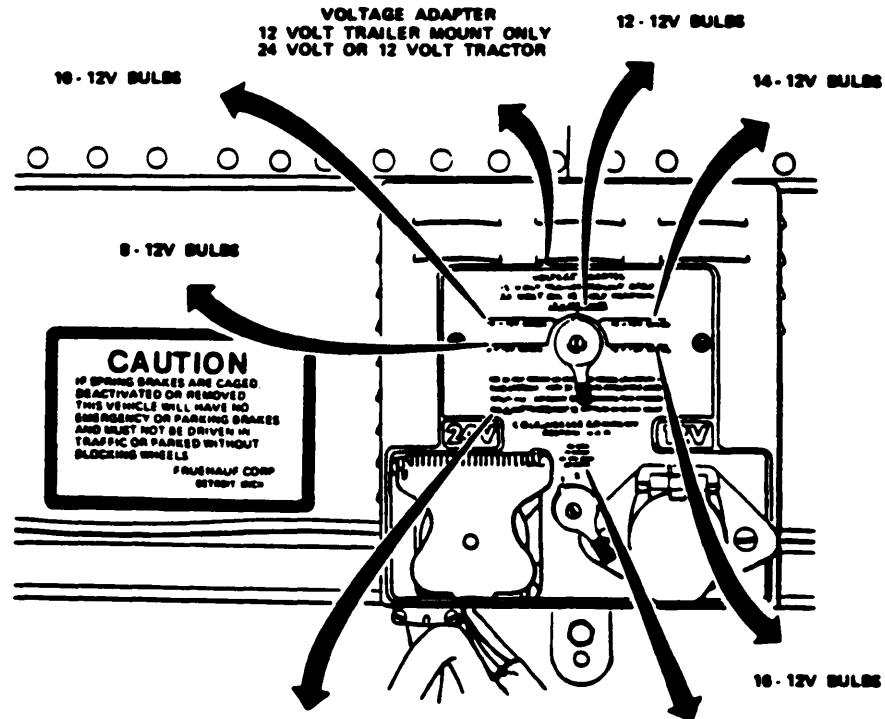

FOR 24 VOLT TRACTOR SET POINTER TO NEAREST LOW NUMBER OF BULBS ON TRAILER. INSERT 24 VOLT PLUG INTO 24 VOLT SOCKET. CAUTION: SET POINTER BEFORE INSERTING PLUG IN SOCKET. FOR 12 VOLT TRACTOR INSERT 12 VOLT PLUG IN 12 VOLT SOCKET.

SET LEVER TO NUMBER OF STOP LAMPS ON TRAILER

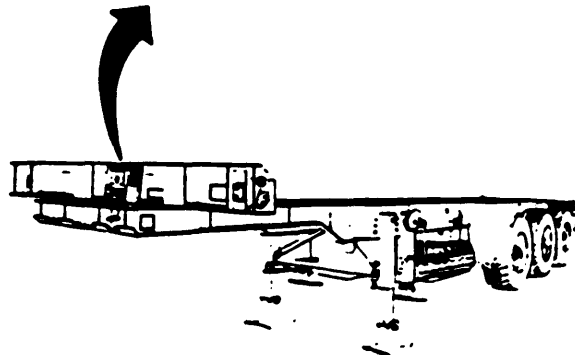

**CAUTION**

**SWITCH MUST BE PLACED IN THE OFF POSITION BEFORE VEHICLE IS MOVED**

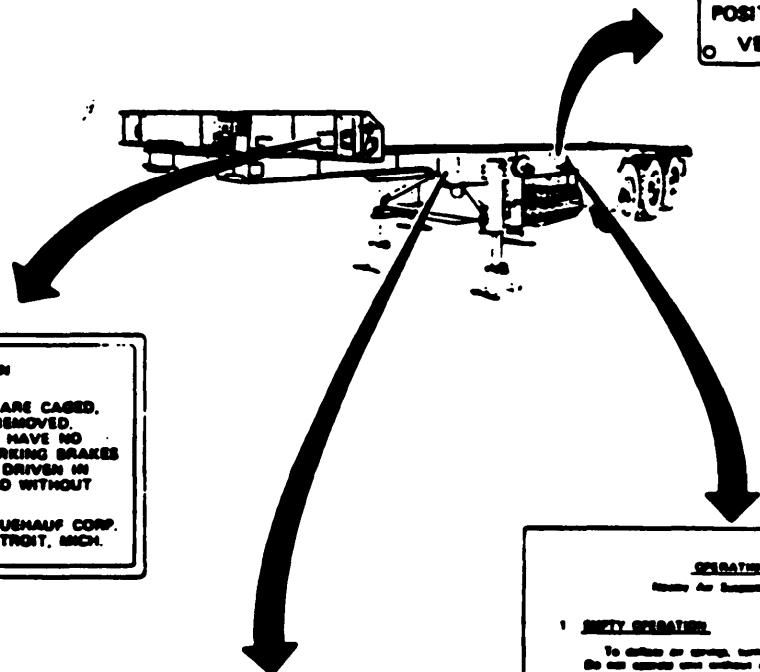
**CAUTION**

**IF SPRING BRAKES ARE CAGED, DEACTIVATED OR REMOVED, THIS VEHICLE WILL HAVE NO EMERGENCY OR PARKING BRAKES AND MUST NOT BE DRIVEN IN TRAFFIC OR PARKED WITHOUT BLOCKING WHEELS**

**FRIEHAUF CORP. DETROIT, MICH.**

**OPERATING INSTRUCTIONS**  
*Refer to Operation and Manual Control*

- EMPTY OPERATOR**  
 To release air spring, turn handle to release position. **CAUTION** Do not operate unit without air pressure present to be above 3 PSI.
- LOADED OPERATOR**  
 To release air spring, move handle to release position until desired pressure is obtained. (Approximately 65 PSI for a 10000 lb. load on dual axle.) When using full capacity use pressure for desired axle load distribution, indicated on chart by moving axle weights and changing air pressure. **CAUTION** Do not operate trailer unless sufficient proper amount of air pressure.
- TRACTOR CONTROL OPERATOR (TRACTORS & TRUCKS)**  
 Move handle to lower pressure position until desired pressure is obtained. By reducing air pressure in dual axle, load will be transferred to other axle. **CAUTION** Do not overload dual axle.
- OPERATOR TO LOADED TRAILER (TRACTOR)**  
 Unlike air spring to a higher pressure has increased axle weight.

**ADJUSTING INSTRUCTIONS**

**ADJUSTING FRONT AIRLINE ADJUSTMENT** See hand valve to determine desired pressure. Do not adjust until axle is empty. Maximum pressure not to be less than 3 PSI.

**ADJUSTING REAR AIRLINE ADJUSTMENT** See hand valve to determine desired pressure. Do not adjust until axle is empty.

REVISION 3/7770

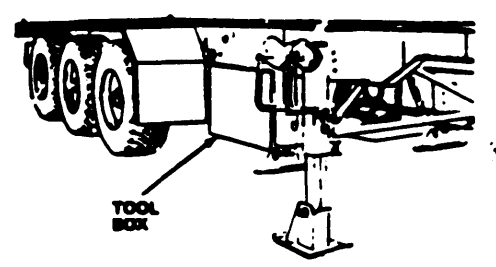
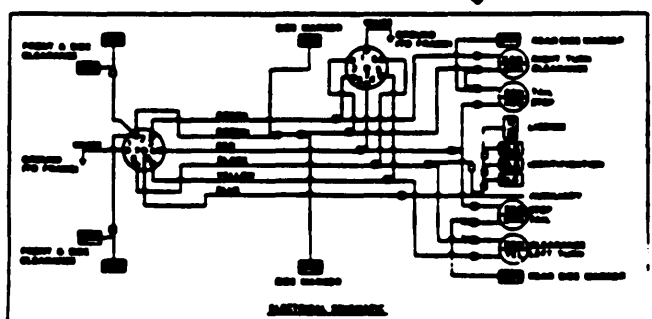

INDEX

SUBJECT PARAGRAPH

TRAILER CHASSIS

A

Ajust Brakes . . . . . 4.4.1.21  
 Ajust Height Control . . . . . 4.4.1.23  
 Air Hose, Replace . . . . . 4.4.1.4  
 Air Spring, Operation . . . . . 1.3.5.8  
 Air Spring, Replace . . . . . 4.4.1.14  
 Air Storage Tanks, Operation . . . . . 1.3.5.1  
 Air Storage Tanks, Moisture Ejector Lanyards . . . . . 2.1.4  
 Air Storage Tanks, Replace . . . . . 5.3.2.7  
 Assembly and Preparation for Use . . . . . 2.3.1  
 Auxiliary Service Relay, Operation . . . . . 1.3.5.5  
 Auxiliary Service Relay, Replace . . . . . 4.4.1.12

B

Back Slap Chamber, Replace . . . . . 4.4.1.11  
 Bearing/Seals, Replace . . . . . 5.3.2.5  
 Brake Chamber, Operation . . . . . 1.3.5.4  
 Brake Chamber, Replace . . . . . 4.4.1.5  
 Brakes, Ajust . . . . . 4.4.1.21  
 Brakes, Replace . . . . . 5.3.2.3  
 Brake System . . . . . 1.3.3  
 Brake System, Operation . . . . . 1.3.6

C

Cam Bearing, Replace . . . . . 5.3.2.2  
 Clearance Lights, Replace . . . . . 3.3.1.2  
 Common Tools and Equipment . . . . . 4.1.1  
 Components, Location and Description of Major . . . . . 1.2.2

D

Data, Equipment . . . . . 1.2.3  
 Decals, Operating Instructions and . . . . . 2.3.3

E

Electrical System . . . . . 1.3.4  
 Equalizer Bushing, Replace . . . . . 4.4.1.16  
 Equipment Data . . . . . 1.2.3  
 Equipment Purpose, Capabilities and Features . . . . . 1.2.1

F

Features, Equipment Purpose, capabilities, and . . . . . 1.2.1  
 Fording . . . . . 2.4.4

INDEX

SUBJECT

Paragraph

TRAILER CHASSIS (CONT)

G

Gage, Replace . . . . . 4.4.1.9

H

Hand Lever Valve, Replace . . . . . 4.4.1.8  
 Height Control Valve . . . . . 1.3.5.6  
 Height Control Valve, Adjust . . . . . 4.4.1.23  
 Height Control Valve, Replace . . . . . 4.4.1.24  
 Hitch Shutoff Valve, Replace . . . . . 4.4.1.13  
 Hub/Drive Assembly, Replace . . . . . 5.3.2.6  
 Hubodometer . . . . . 2.1.5  
 Hubodometer, Replace . . . . . 4.4.1.26

I

Identification Lights, Replace . . . . . 3.3.1.2  
 Improvements, Reporting Equipment . . . . . 1.1.3  
 Information, Warranty . . . . . 1.1.4  
 Instructions, Lubrication . . . . . 3.1.1

L

Landing Gear Assembly, Replace . . . . . 4.4.1.10  
 Leveling Jack, Repair . . . . . 5.3.2.4  
 Leveling Jack, Replace . . . . . 4.4.1.22  
 License Plate Light, Replace . . . . . 3.3.1.1  
 Location and Description of Major Components . . . . . 1.2.2  
 Lubrication Instructions . . . . . 3.1.1

M

Main Frame Assembly . . . . . 1.2.1  
 Maintenance Forms and Records . . . . . 1.1.2  
 Maintenance Procedures:  
     Direct/General Support . . . . . 5.3.1  
     Operator's . . . . . 3.3.1  
     Organizational . . . . . 4.4.1  
 Marker Lights, Replace . . . . . 3.3.1.2  
 Moisture Ejector, Replace . . . . . 4.4.1.18

O

Operating Instructions and Decals . . . . . 2.3.3  
 Operation, Brake System . . . . . 1.3.6  
 Operation in Cold Weather . . . . . 2.4.1



I N D E X

SUBJECT	PARAGAPH
TRAILER CHASSIS (Cont)	
Operation in Dusty and Sandy Areas . . . . .	2.4.3
Operation in Extreme Heat . . . . .	2.4.2
Operation, Override Assembly Pilot Valve . . . . .	1.3.7
Override Assembly, Controls and Indicators . . . . .	2.1.2
Override Assembly, Operation . . . . .	1.3.5.7
Override Assenbly Pilot Valve Operation . . . . .	1.3.7
Override Valve Selector, Replace . . . . .	4.4.1.6
P	
Parking . . . . .	2.3.2
Pilot Valve, Replace . . . . .	4.4.1.7
Pneumatic System. . . . .	1.3.5
Preparation for Storage or Shipment . . . . .	4.5.1
Preventive Maintenance Checks and Services:	
Operator's . . . . .	2.2.1
Organizational . . . . .	4.2.1
Procedures, Maintenance:	
Direct/General Support . . . . .	5.3.1
Operator's . . . . .	3.3.1
organizational . . . . .	4.3.1
R	
Ratio Relay Valve, operation . . . . .	1.3.5.3
Ratio Relay Valve, Replace . . . . .	4.4.1.2
Records, Maintenance Form and... . . . .	1.1.2
Reflector, Replace . . . . .	4.4.1.1.9
Relay Quick Release Valves, Operation . . . . .	1.3.5.2
Relay Quick Release Valves, Replace . . . . .	4.4.1.3
Repair Landing Gear Assembly, . . . . .	5.3.2.1
Repair Leveling Jack.. . . . .	5.3.2.4
Repair Parts. . . . .	4.1.3
Repair Parts; Special Tools; Test, Measurement, and Diagnostic Equipment; and Support Equipment . . . . .	5.1.1
Replace:	
Air Hose. . . . .	4.4.1.4
Air Hoses . . . . .	4.4.1.25
Air Spring. . . . .	4.4.1.14
Air Tank . . . . .	5.3.2.7
Auxiliary Service Relay . . . . .	4.4.1.12
Basic Slap Chamber . . . . .	4.4.1.11
Brake Chamber . . . . .	4.4.1.5
Brakes . . . . .	5.3.2.3
Bearing/Seals . . . . .	5.3.2.5
Cam Bearing . . . . .	5.3.2.2
Equalizer Bushing . . . . .	4.4.1.16
Gage. . . . .	4.4.1.9

INDEX

SUBJECT	PARAGRAPH
TRAILER CHASSIS (Cont)	
Hand Level Valve . . . . .	4 . 4 . 1 . 8
Height Control Valve . . . . .	4 . 4 . 1 . 24
Hitch Shutoff Valve . . . . .	4 . 4 . 1 . 13
Hub/Drive Assembly . . . . .	5 . 3 . 2 . 6
Hubodometer . . . . .	4 . 4 . 1 . 26
Landing Gear Assembly . . . . .	4 . 4 . 1 . 10
Leveling Jack . . . . .	4 . 4 . 1 . 22
Licence Plate Light . . . . .	3 . 3 . 1 . 1
Marker and Identification Lights Clearance . . . . .	3 . 3 . 1 . 2
Moisture Ejector . . . . .	4 . 4 . 1 . 18
Override Valve Selector . . . . .	4 . 4 . 1 . 7
Pilot Valve . . . . .	1 . 4 . 5 . 15
Ratio Relay Valve. . . . .	4 . 4 . 1 . 19
Reflector . . . . .	4 . 4 . 1 . 3
Relay Quick Release Valve . . . . .	4 . 4 . 1 . 15
Shock Absorber . . . . .	3 . 3 . 1 . 3
Stop Lights, Turn Signals and Tail Lights . . . . .	4 . 4 . 1 . 1
Tires . . . . .	4 . 4 . 1 . 17
U-Bolts . . . . .	4 . 4 . 1 . 20
Voltage Control Unit . . . . .	4 . 4 . 1 . 20
Reporting Equipment Improvements (EIR's) . . . . .	1 . 1 . 3

S

Scope . . . . .	1.1.1
Services, Preventive Maintenance Checks and:	
Operator's . . . . .	2 . 2 . 1
Organizational . . . . .	4 . 2 . 1
Shipment, Preparation for Storage or . . . . .	4 . 5 . 1
Shock Absorber, Replace . . . . .	4.4.1.15
Special Tools; Test, Measurement, and Diagnostic Equipment; and Support Equipment . . . . .	4.1.2 3.3.1.3
Stoplights, Replace . . . . .	2.1.3
Support, Leveling and Locking . . . . .	1.3.2
Suspension System . . . . .	

T

Tail Lights, Replace . . . . .	3.3.1.3
Tires, Replace . . . . .	4.4.1.1
Troubleshooting:	
Direct/General Support . . . . .	5.2.1
Operator's . . . . .	3.2.1
Organizational . . . . .	4.3.1
Turn Signals, Replace . . . . .	3.3.1.3

INDEX

SUBJECT PARAGRAPH

TRAILER CHASSIS (Cont)

U

U-Bolts, Replace . . . . . 4.4.1.17

V

Voltage Control Unit, Controls and Indicators . . . . . 2.1.1

Voltage Control Unit, Replace . . . . . 4.4.1.20

W

Warranty Information . . . . . 1.1.4



By Order of the Secretary of the Army:

**E. C. MEYER**  
General, *United States Army*  
Chief of Staff

Official:

**ROBERT M. JOYCE**  
Major General, *United States Army*  
The Adjutant General

DISTRIBUTION:

To be distributed in accordance with DA Form 12-25A, Operator Maintenance requirements for Mapping.

☆ U.S. GOVERNMENT PRINTING OFFICE : 1995 O - 388-421 (02551)





THEN... JOT DOWN THE DOPE ABOUT IT ON THIS FORM. CAREFULLY TEAR IT OUT. FOLD IT AND DROP IT IN THE MAIL!

SOMETHING WRONG WITH THIS PUBLICATION?

FROM (PRINT YOUR UNIT'S COMPLETE ADDRESS)  
**PFC JOHN DOE**  
**COA, 3d ENGINEER BN**  
**FT. LEANBARWOOD, MD 63108**  
 DATE SENT

PUBLICATION NUMBER: **TM 5-2330-305-14**  
 PUBLICATION DATE: **6 Jun 83**  
 PUBLICATION TITLE: **Topographic Support System Trailer (ADCOR)**

BE EXACT PIN-POINT WHERE IT IS				IN THIS SPACE TELL WHAT IS WRONG AND WHAT SHOULD BE DONE ABOUT IT:
PAGE NO	PARA-GRAPH	FIGURE NO	TABLE NO	
<b>6</b>	<b>2-1 a</b>			<i>In line 6 of paragraph 2-1a the manual states the engine has <u>6</u> Cylinders. The engine on my set only has <u>4</u> Cylinders. Change the manual to show <u>4</u> Cylinders.</i>
<b>B1</b>		<b>4-3</b>		<i>Callout 16 on figure 4-3 is pointing at a <u>bolt</u>. In key to figure 4-3, item 16 is called a <u>skin</u> - Please correct one or the other.</i>
<b>125</b>	<b>line 20</b>			<i>I ordered a gasket, item 19 on figure B-16 by NSN 2 910-05-762-3001. I got a gasket but it doesn't fit. Supply says I got what I ordered, so the NSN is wrong. Please give me a good NSN</i>

PRINTED NAME, GRADE OR TITLE AND TELEPHONE NUMBER: **JOHN DOE, PFC (262) 317-7111**  
 SIGN HERE: **JOHN DOE**

DA FORM 2028-2  
 1 JUL 79

PREVIOUS EDITIONS ARE OBSOLETE.  
 DRSTS-M Overprint 1, 1 Nov 80

PS--IF YOUR OUTFIT WANTS TO KNOW ABOUT YOUR RECOMMENDATION MAKE A CARBON COPY OF THIS AND GIVE IT TO YOUR HEADQUARTERS

TEAR ALONG PERFORATED LINE

FILL IN YOUR  
UNIT'S ADDRESS

FOLD BACK

DEPARTMENT OF THE ARMY

\_\_\_\_\_  
\_\_\_\_\_

OFFICIAL BUSINESS

COMMANDER  
U S ARMY SUPPORT AND AVIATION MATERIEL READINESS COMMAND  
ATTN: DRSTS-MPSD  
4300 GOODFELLOW BOULEVARD  
ST. LOUIS, MO 63120

TEAR ALONG PERFORATED LINE





FILL IN YOUR  
UNIT'S ADDRESS

FOLD BACK

DEPARTMENT OF THE ARMY

\_\_\_\_\_  
\_\_\_\_\_

OFFICIAL BUSINESS

COMMANDER  
U S ARMY SUPPORT AND AVIATION MATERIEL READINESS COMMAND  
ATTN: DRSTS-MPSD  
4300 GOODFELLOW BOULEVARD  
ST. LOUIS, MO 63120

TEAR ALONG PERFORATED LINE



FILL IN YOUR  
UNIT'S ADDRESS

FOLD BACK

DEPARTMENT OF THE ARMY

OFFICIAL BUSINESS

COMMANDER  
U S ARMY SUPPORT AND AVIATION MATERIEL READINESS COMMAND  
ATTN: DRSTS-MPSD  
4300 GOODFELLOW BOULEVARD  
ST. LOUIS, MO 63129

THIS AREA PERFORATED LINE



FILL IN YOUR  
UNIT'S ADDRESS

FOLO BACX

DEPARTMENT OF THE ARMY

OFFICIAL BUSINESS

COMMANDER  
U S ARMY SUPPORT AND AVIATION MATERIEL READINESS COMMAND  
ATTN: DRSTS-MPSD  
4300 GOODFELLOW BOULEVARD  
ST. LOUIS, MO 63120

TEAR ALONG PERFORATED LINE

# The Metric System and Equivalents

## Linear Measure

1 centimeter = 10 millimeters = .39 inch  
 1 decimeter = 10 centimeters = 3.94 inches  
 1 meter = 10 decimeters = 39.37 inches  
 1 dekameter = 10 meters = 32.8 feet  
 1 hectometer = 10 dekameters = 328.08 feet  
 1 kilometer = 10 hectometers = 3,280.8 feet

## Weights

1 centigram = 10 milligrams = .15 grain  
 1 decigram = 10 centigrams = 1.54 grains  
 1 gram = 10 decigrams = .035 ounce  
 1 dekagram = 10 grams = .35 ounce  
 1 hectogram = 10 dekagrams = 3.52 ounces  
 1 kilogram = 10 hectograms = 2.2 pounds  
 1 quintal = 100 kilograms = 220.46 pounds  
 1 metric ton = 10 quintals = 1.1 short tons

## Liquid Measure

1 centiliter = 10 milliliters = .34 fl. ounce  
 1 deciliter = 10 centiliters = 3.38 fl. ounces  
 1 liter = 10 deciliters = 33.81 fl. ounces  
 1 dekaliter = 10 liters = 2.64 gallons  
 1 hectoliter = 10 dekaliters = 26.42 gallons  
 1 kiloliter = 10 hectoliters = 264.18 gallons

## Square Measure

1 sq. centimeter = 100 sq. millimeters = .155 sq. inch  
 1 sq. decimeter = 100 sq. centimeters = 15.5 sq. inches  
 1 sq. meter (centare) = 100 sq. decimeters = 10.76 sq. feet  
 1 sq. dekameter (are) = 100 sq. meters = 1,076.4 sq. feet  
 1 sq. hectometer (hectare) = 100 sq. dekameters = 2.47 acres  
 1 sq. kilometer = 100 sq. hectometers = .386 sq. mile

## Cubic Measure

1 cu. centimeter = 1000 cu. millimeters = .06 cu. inch  
 1 cu. decimeter = 1000 cu. centimeters = 61.02 cu. inches  
 1 cu. meter = 1000 cu. decimeters = 35.31 cu. feet

## Approximate Conversion Factors

To change	To	Multiply by	To change	To	Multiply by
inches	centimeters	2.540	ounce-inches	newton-meters	.007062
feet	meters	.305	centimeters	inches	.394
yards	meters	.914	meters	feet	3.280
miles	kilometers	1.609	meters	yards	1.094
square inches	square centimeters	6.451	kilometers	miles	.621
square feet	square meters	.093	square centimeters	square inches	.155
square yards	square meters	.836	square meters	square feet	10.764
square miles	square kilometers	2.590	square meters	square yards	1.196
acres	square hectometers	.405	square kilometers	square miles	.386
cubic feet	cubic meters	.028	square hectometers	acres	2.471
cubic yards	cubic meters	.765	cubic meters	cubic feet	35.315
fluid ounces	milliliters	29.573	cubic meters	cubic yards	1.308
pints	liters	.473	milliliters	fluid ounces	.034
quarts	liters	.946	liters	pints	2.113
gallons	liters	3.785	liters	quarts	1.057
ounces	grams	28.349	liters	gallons	.264
pounds	kilograms	.454	grams	ounces	.035
short tons	metric tons	.907	kilograms	pounds	2.205
pound-feet	newton-meters	1.356	metric tons	short tons	1.102
pound-inches	newton-meters	.11296			

## Temperature (Exact)

°F	Fahrenheit temperature	5/9 (after subtracting 32)	Celsius temperature	°C
----	------------------------	----------------------------	---------------------	----

